

Principle of Operation

Liquid enters a precision-machined chamber containing an oscillating (rotating) piston. The position of the piston divides the chamber into compartments containing an exact volume. Liquid pressure drives the piston to oscillate and rotate its center hub. The movements of the hub are sensed through the meter cover by a follower magnet. Each revolution of the piston hub is equivalent to a fixed volume of fluid, which is indicated as flow by a register/totalizer. Close clearances between the piston and the chamber ensure minimum liquid slip for highly accurate and repeatable measurement of each volume cycle.



Figure 1. Oscillating Piston with R-22 register



Figure 2. Oscillating Piston with R-15 register

Accessories

- Two-stage shut-off valves
- Rate of flow indicators
- Totalizers
- Batch controllers

Benefits

High Accuracy	± 0.5% of rate
Exceptional Value	Eliminates upstream and downstream straight run piping requirements Power not required for mechanical version
Reliable Design and Construction	Standard 316 SS/ETFE allows user flexibility with different fluids

Technical Information

Functional Specifications

Fluid Types	Liquid
Maximum Pressure	275 psig (19 bar)
Fluid Temperature	32° to 150° F (0° to 66°C)
Registration	U.S. gallons/lbs./Imperial gallons/Liters - register and dependent
Outputs	Mechanical totalizing, mechanical batching, electro-mechanical totalizing, electro-mechanical batching, and blind electronic pulse registers available. See Registers section beginning on page 44.

Performance Specifications

Accuracy	± 0.5% of rate
Repeatability	± 0.1% of rate
Flow Turndown Ratio	10:1
Flow Range	see Table 1
Agency Approvals	UL and CSA Class 1 Div 1 Group D Display and Totalizer Available R-22 Registers Only

Physical Specifications

Materials of Construction	
Case	316 SS
Chamber	316 SS
Flanges	316 SS
Piston	ETFE
Seals	Teflon® encapsulated silicon rubber
Register Housing	Plastic, Bronze, Aluminum (See section beginning on Page 44)
Connections & Mountings	
Mounting Position	Horizontal, Angle. Ensure meter remains full with register up
Typical Straight Pipe Requirements	Upstream 0 x D Downstream 0 x D
Process Connections	ANSI Class 150 RF
Electrical Connection	Only for optional electronic transmitter

Flow Ranges/Accuracy

Water flow rates at standard conditions
Minimum and maximum flow rates to achieve accuracy

Line Size (inch)	1		2	
	min	max	min	max
GPM	7.0	70.0	15.0	150.0
L/MIN	26.5	264.9	56.8	567.8

Table 1

Pressure Loss Vs. Flow Rate

Flow rate USGPM water at 60° F

On Water

1" HPM Flowmeter Accuracy

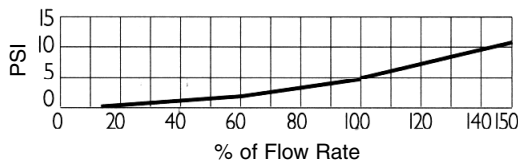

2" HPM Flowmeter Accuracy

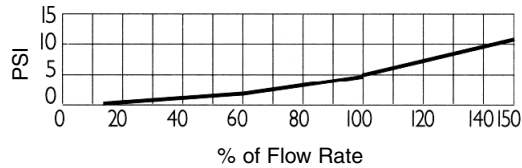

Different Viscosities (cP)

1" HPM Flowmeter Accuracy

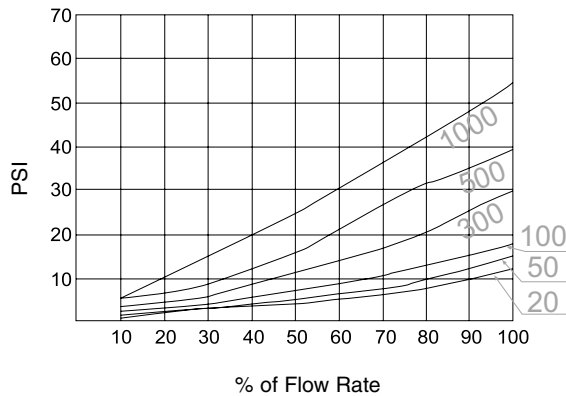

2" HPM Flowmeter Accuracy

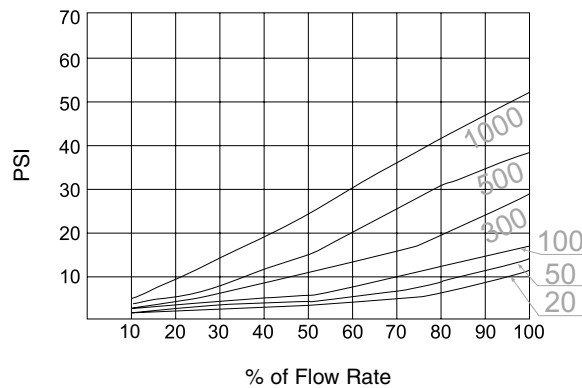

Dimensions

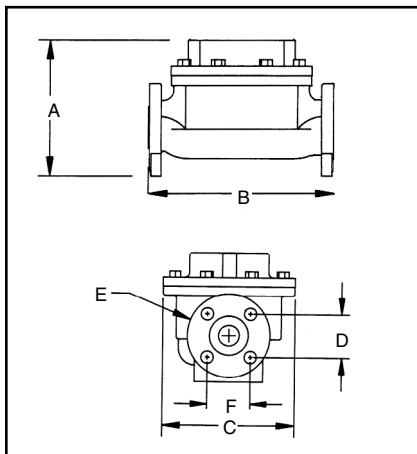

Figure 3

	1" meter		2" meter	
	inches	millimeters	inches	millimeters
A	6 9/16"	166.69	7 1/4"	184.15
B	9"	228.60	13"	330.20
C	6 7/8"	174.63	9 3/8"	238.13
D	2 1/4"	57.15	3 3/8"	85.73
E	4 1/4"	107.95	6"	152.40
F	2 1/4"	57.15	3 3/8"	85.73
Weight**	21lbs	9.53 kg	44 lbs	19.96 kg

**meter only

Table 2

Ordering Information

Please provide completed application data sheet (found at www.aaliant.com) to allow us to confirm selection.

1. Confirm minimum and maximum flow ranges to maintain stated accuracy from Table 1 are within your requirements.
2. Select line size.
3. Select Register/Transmitter from below.

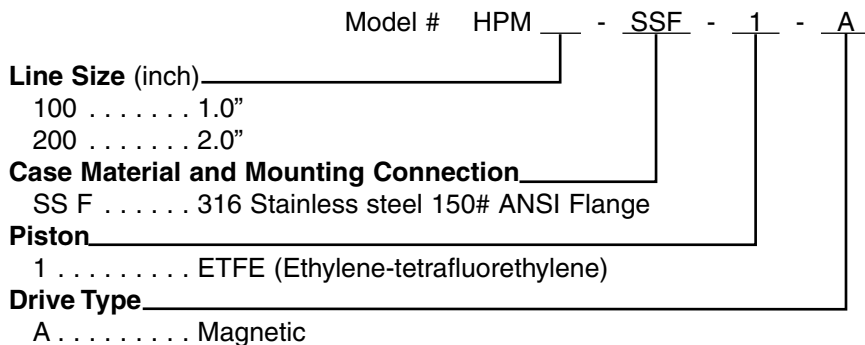

Registers and Transmitters

Model #	Description
R-10	Horizontal, mechanical, non-resettable total
R-11	Blind transmitter with dry contact closure
R-15A	Horizontal, mechanical, non-resettable total
R-15B	Horizontal, mechanical w/ transmitter, non-resettable total with contact closure
R-20	Vertical, mechanical non-resettable with 6" dial
R-22A	Vertical, mechanical totalizer and resettable totalizer
R-22B	Vertical, mechanical w/ transmitter, totalizer and resettable totalizer with contact closure
R-22C	Vertical, mechanical w/ transmitter, totalizer and resettable totalizer with digital pulse, explosion proof
R-25	Blind transmitter with digital pulse, explosion proof
R-30A	Vertical, mechanical w/ transmitter, non-resettable total, 6" dial, contact closure at batch
R-30C	Vertical, mechanical w/ transmitter, non-resettable total, 6" dial, contact closure at zero point
R-30D	Vertical, mechanical w/ pulse transmitter, non-resettable total, 6" dial, contact closure per unit
R-31C	Vertical, mechanical w/ transmitter, non-resettable total, 6" dial, contact closure at zero, explosion proof
R-35	Mechanical batch controller, 1.0" stainless steel valve
R-35	Mechanical batch controller, 2.0" stainless steel valve