



General Information

These "hot tap" versions of the proven IP insertion flow sensors are designed to install or be serviced without depressurizing the pipe. Like all IP sensors, they have a paddlewheel rotor and jewel bearings for superior low-flow performance. Rotation of the rotor is detected by a non-drag Hall-effect sensor, which interfaces easily with many types of electronic control. A display, divider, or analog transmitter can be installed on the end of the sensor, or the signal can be sent without amplification for hundreds of feet to remote electronics.

Insertion and removal under pressure is possible due to the 2" full-port isolation valve, which comes with a nipple for installation on the pipe fitting. If it is necessary to do the initial installation under pressure, any standard hot tap drilling machine with 2" NPT adapter, such as a Transmate or a Mueller, can be used. Ordinarily, it is not necessary to use an installation tool, since the small-diameter tube can be controlled by hand at all but the highest pressures.

Specifications

Materials

Sensor Body	Brass, 316 SS, PVC
Rotor	PVDF
Shaft	Nickel-bound tungsten carbide or zirconia ceramic optional
Bearings	Ruby
Valve	
PVC	2" Gate valve
Brass & SS	Bronze STD, 316SS optional

Range 0.3 - 30 FPS (0.1 - 9 M/s)

Accuracy ± 1-1/2% FS

Maximum Pressure

PVC	150 psi (10 bar)
Brass & SS	250 psi (17 bar)

Insertion Force 0.44 X pressure in pipe

Pipe Size

IP 115	2" - 10" (50-250mm)
IP 215	10" - 48" (250 -1200mm)

Temperature

PVC	140° F (60°C) @ 0 psi
Brass & SS	250° F (121°C)

Fitting Size

2" NPT

Power

5-24 VDC 1.5 mA

Sensor/Signal

Hall Effect (NPN) current sinking pulse, 20 mA maximum

Nominal K-factor

11 Hz / FPS (3.6 Hz/M/s)

Cable

#22 AWG 3-con, 18' (6m)

Maximum Cable Run

2,000' (650m)

Features

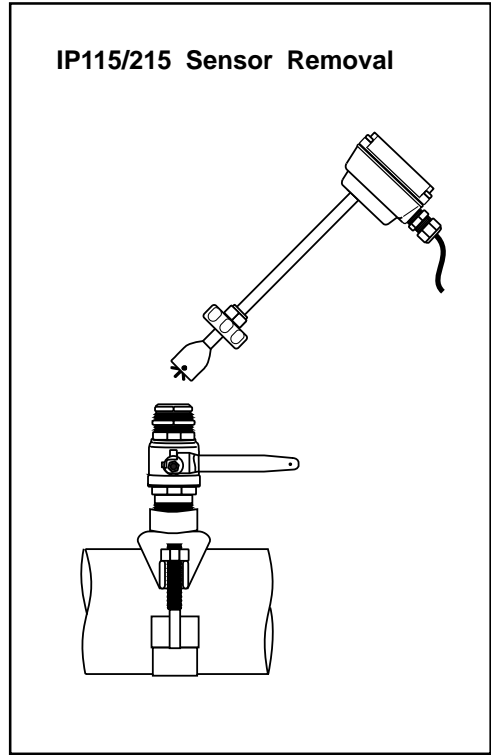
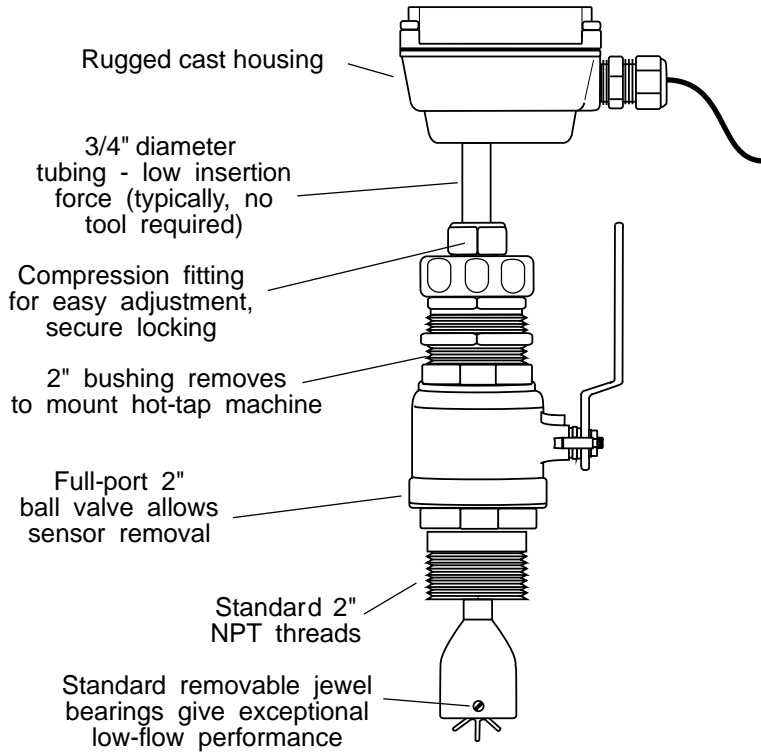

Flow Range (GPM)

Pipe Size	Min Flow	Max Flow
2	3	300
3	7	700
4	12	1,100
6	30	2,500
8	50	4,500
10	75	7,000
12	100	10,000
16	175	16,000
24	400	35,000

Dimensions

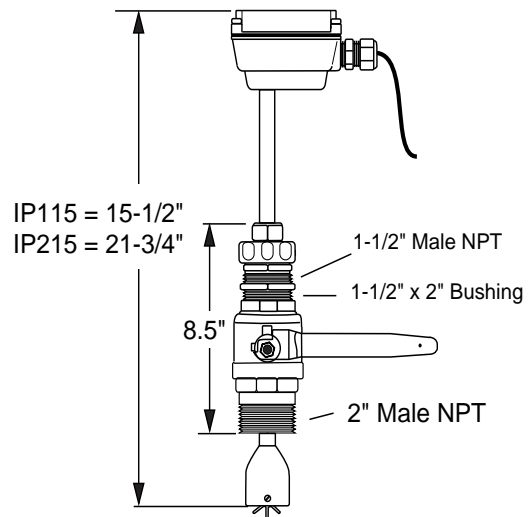

How To Order

Material code: P = PVC, B = Brass, S = 316 SS

Option Code: (See options to right)

IP115 - _____ - _____
IP215 - _____ - _____

Option Codes

- 01 Ceramic shaft
- 03 Bidirectional flow (Hall-Effect only)
- 06 LMI connector
- 07 SeaMetrics connector

SeaMetrics