

MODEL MG/MS100

DESCRIPTION

Model MG100 and MS100 meters are designed to provide high pressure rating and "Main Line" meter accuracy in an inexpensive package. The flowmeters are manufactured to comply with the applicable provisions of the American Water Works Association Standard No. C704-92 for propeller type flowmeters. The impeller and drive assembly are fully accessible through the open end of the meter tube.

Impellers are manufactured of high-impact plastic, capable of retaining their shape and accuracy over the life of the meter. Each impeller is individually calibrated at the factory to accommodate the use of any standard McCrometer register, and since no change gears are used, the flowmeters can be field-serviced without the need for factory recalibration. Factory lubricated, stainless steel bearings are used to support the impeller shaft. The

shielded bearing design limits the entry of materials and fluids into the bearing chamber providing maximum bearing protection.

An instantaneous flowrate indicator is standard and available in gallons per minute, cubic feet per second, liters per second and other units. The register is driven by a flexible steel cable encased within a protective vinyl liner. The register housing protects both the register and cable drive system from moisture while allowing clear reading of the flowrate indicator and totalizer.

INSTALLATION

Standard installation is horizontal mount. If the meter is to be mounted in the vertical position, please advise the factory. A straight run of full pipe the length of five diameters ahead and one diameter behind the meter is the minimum normally recommended.



The McCrometer Propeller flowmeter comes with a standard instantaneous flowrate indicator and straight-reading totalizer. An optional electronic register is also available.
Typical face plates.



APPLICATIONS

The McCrometer propeller meter is the most widely used flowmeter for municipal and wastewater treatment applications as well as agricultural and turf irrigation measurement. Typical applications include:

- Center pivot systems
- Sprinkler irrigation systems
- Drip irrigation systems
- Golf course and park water management
- Gravity turnouts from underground pipelines
- Commercial Nurseries
- Water and Wastewater management



GROOVED & SMOOTH-END FLOWMETER MODEL MG/MS100

SPECIFICATIONS

PERFORMANCE

ACCURACY/REPEATABILITY: $\pm 2\%$ of reading guaranteed throughout full range. $\pm 1\%$ over reduced range. Repeatability 0.25% or better.

RANGE: (see dimensions chart below)

HEAD LOSS: (see dimensions chart below)

MAXIMUM TEMPERATURE: (Standard Construction)
160°F constant

PRESSURE RATING: 150 psi

MATERIALS

TUBE: Epoxy-coated carbon steel.

BEARING ASSEMBLY: Impeller shaft is 316 stainless steel.

Ball bearings are 440C stainless steel.

MAGNETS: (Permanent type) Cast or sintered alnico

BEARING HOUSING: Brass; Stainless Steel optional

IMPELLER: Impellers are manufactured of high-impact plastic, retaining their shape and accuracy over the life of the meter. High temperature impeller is optional.

REGISTER: An instantaneous flowrate indicator and six-digit straight-reading totalizer are standard. The register is hermetically sealed within a die cast aluminum case. This protective housing includes a domed acrylic lens and hinged lens cover with locking hasp.

COATING: Fusion-bonded epoxy

OPTIONS

- Forward/reverse flow measurement
- High temperature construction
- "Over Run" bearing assembly for higher-than-normal flowrates
- Electronic Propeller Meter available in all sizes of this model
- A complete line of flow recording/control instrumentation
- Straightening vanes and register extensions available
- Certified calibration test results

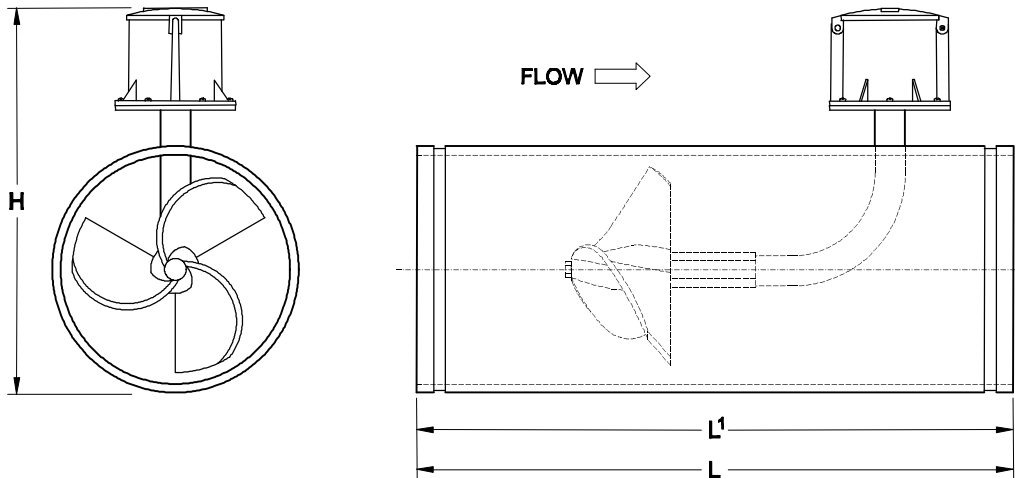

McCrometer reserves the right to change design or specifications without notice.

MG100 / MS100	DIMENSIONS												
Meter Size (inches)	2	2 ½	3	4	6	8	10	12	14	16	18	20	24
Maximum Flow U.S. GPM	* See Special Note		250	600	1200	1500	1800	2500	3000	4000	5000	6000	8500
Minimum Flow U.S. GPM			35	50	90	100	125	150	250	275	400	475	700
Head Loss in Inches at Max. Flow			29.50	23.00	17.00	6.75	3.75	2.75	2.00	1.75	1.50	1.25	1.00
Shipping Weight, lbs.			17	40	54	68	87	106	140	144	172	181	223
H (inches)			10.9	12.78	13.84	14.84	16.91	18.90	20.53	22.53	25.53	26.53	30.53
L (inches) MG100			13	20	20	20	20	20	20	22	22	22	22
L ¹ (inches) MS100			13	20	22	22	22	22	22	24	24	24	24
O.D. of Meter Tube	3.50	4.500	6.625	8.625	10.750	12.750	14.00	16.00	18.00	20.00	24.00		

*Special Note—Reducing fittings incorporating vanes are available to adapt the 3-inch model to smaller line sizes. Minimum flow for 3-inch pipe still applies.

Larger flowmeters on special order.

FOR MORE INFORMATION CONTACT:



3255 West Stetson Avenue
Hemet CA 92545-7799 USA
909-652-6811 / FAX 909-652-3078
e-mail: info@mccrometer.com
Web Site: http://www.mccrometer.com