

SAVE THESE INSTRUCTIONS



5252 East 36th Street North
Wichita, KS USA 67220-3205
TEL: 316-686-7361
FAX: 316-686-6746

GREAT PLAINS INDUSTRIES, INC.

"A Great Plains Ventures Subsidiary"

www.gpi.net

1-888-996-3837

Industrial Grade Remote Transmitter Pulse Out with Display

Owner's Manual

Manual No. 920765-02

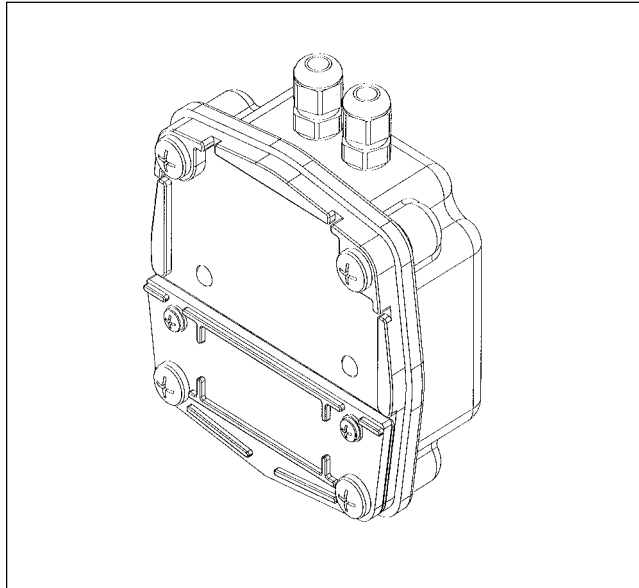

To the owner...

Congratulations on receiving your GPI Remote Transmitter. We are pleased to provide you with a product designed to give you maximum reliability and efficiency.

Our business is the design, manufacture, and marketing of liquid handling, agricultural, and recreational products. We succeed because we provide customers with innovative, reliable, safe, timely, and competitively-priced products. We pride ourselves in conducting our business with integrity and professionalism.

We are proud to provide you with a quality product and the support you need to obtain years of safe, dependable service.

President
Great Plains Industries, Inc.

TABLE OF CONTENTS

General Information	1
Product Description	1
Safety Instructions	2
Installation	2
Wiring	2
Operations	4
Maintenance	6
Troubleshooting	6
Dimensions	8
Specifications	9
Parts List	10
Service	10

GENERAL INFORMATION

This manual will assist you in operating and maintaining the computer electronics of the GPI Remote Transmitter. Included in this manual is information on calibrating the transmitter display and wiring the pulse output to your equipment.

This manual is for use with GPI A2 Series Turbine Meters only (Models 050, 100, 150, 200, and 250 in stainless steel, PVC, PVDF, brass, and aluminum).

The Remote Transmitter can be configured to provide Remote Display (using *Conditioned Signal Sensor* or *Standard*

Remote options) or Local and Remote Display (using Turbine Mounted Display option). Details on using the transmitter with other meters can be obtained from GPI customer service.

PRODUCT DESCRIPTION

The GPI Remote Transmitter is a flow totalizer and rate meter with industry standard pulse output. The Remote Transmitter accepts input pulses from a turbine meter or other frequency generating meter, and uses those pulses to calculate the flow total and rate in a pipeline. The transmitter is powered by customer-supplied external power. The transmitter can be pipe, wall, or panel mounted.

The electronics provides the options of local (on the meter) and/or remote (up to 5,000 feet) display. Flow total and rate are displayed on a large 6-digit LCD readout with two-point floating decimal for totals from .01 to 999,999. All operations are easily accessed with the push buttons on the display front panel.

CAUTION

This transmitter is not yet FM Approved. Therefore, use of this transmitter with an approved metering system voids FM Approval.

NOTE: This transmitter is externally powered, requiring an input power supply of 8.5 to 35 volts (24 VDC is recommended).

SAFETY INSTRUCTIONS

- When measuring flammable liquids, observe precautions against fire or explosion.
- When working in hazardous environments, always exercise appropriate safety precautions.
- When applying external power to the transmitter, use DC power only.
- Disconnect external power to the transmitter before detaching or attaching input or output wires.
- Ground loops between sensor and user equipment can damage the transmitter and can be dangerous.
- If you cannot galvanically isolate the sensor from earth ground, you may need to use the transmitter's optically isolated inputs.
- Be sure O-rings and seals are kept in good repair.

INSTALLATION

⚠ CAUTION

Installation should be performed only by qualified personnel, and in accordance with local governing regulations.

Environmental

Choose a mounting location suitable for the remote transmitter. The ideal mounting location is where the:

- turbine meter is as close as possible.
- mounting surface has minimal vibration.
- ambient temperature is +30°F to 140°F (0°C to 60°C) when using remote display.
- cable lengths are minimal.

Avoid mounting locations where the remote transmitter is:

- subject to constant exposure to water or other liquids (occasional low-pressure splashing will not harm unit if cable entry points are well-sealed).
- subject to > 5g shock loading.
- facing the sun directly for long periods of time.
- close to high voltage/current runs, DC motors, internal combustion engines, or frequency inverters.

Sensor Cabling

- GPI A2 Turbine Sensors are sold as part of the Remote Transmitter and come with 20 ft. of shielded cable.
- If you require a longer cable, a 100 ft. cable kit is available from GPI, or use Belden 9363 cable. When wiring longer lengths of cable, be sure to connect the shield to transmitter LOCAL-COM ONLY! (Multiple shield connections may cause ground-loop problems).
- Some trial and error may be needed because of the wide variety of user conditions. Try to keep cable lengths short!

WIRING

If you ordered your Remote Transmitter to use with a GPI A2 Industrial Meter, the transmitter comes with 20 ft. of cable to connect to the meter. The customer must supply the power supply. Connect the power source to the LOOP (+) and LOOP (-) terminals, as shown in the following diagrams.

Connecting the Equipment:

- Remove the faceplate by removing the four (4) corner screws.
- Attach wiring from your equipment according to the following terminal connections and wiring diagrams, depending on your circumstances.

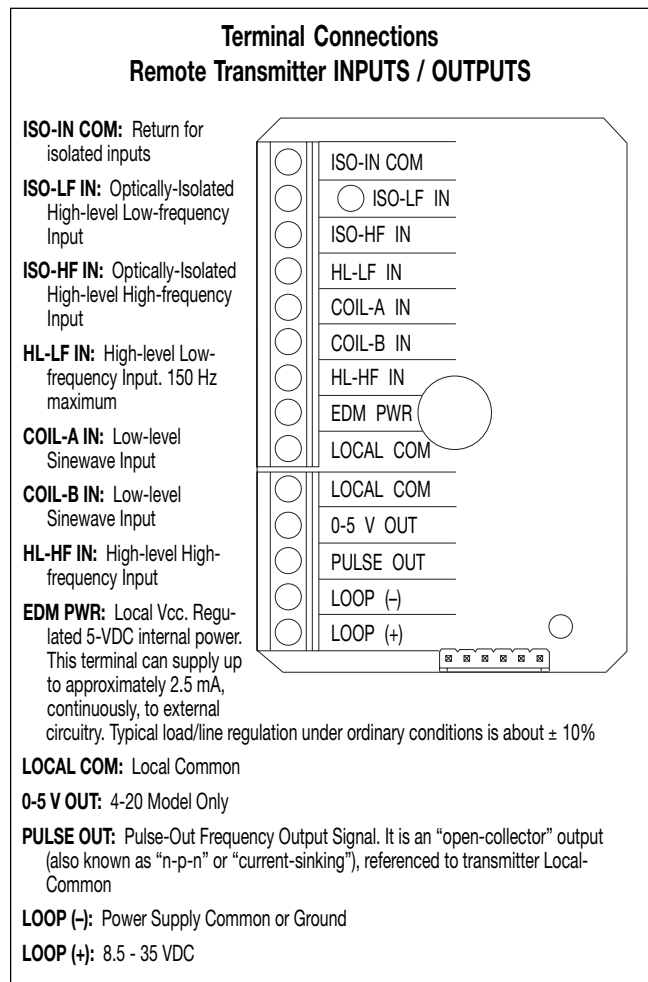

WIRING DIAGRAM 1

**— GPI A2-Series Turbine with Local Display & Conditioned Signal Option —
Customer Equipment with Frequency Sensing and Separate Loop Power Supply**

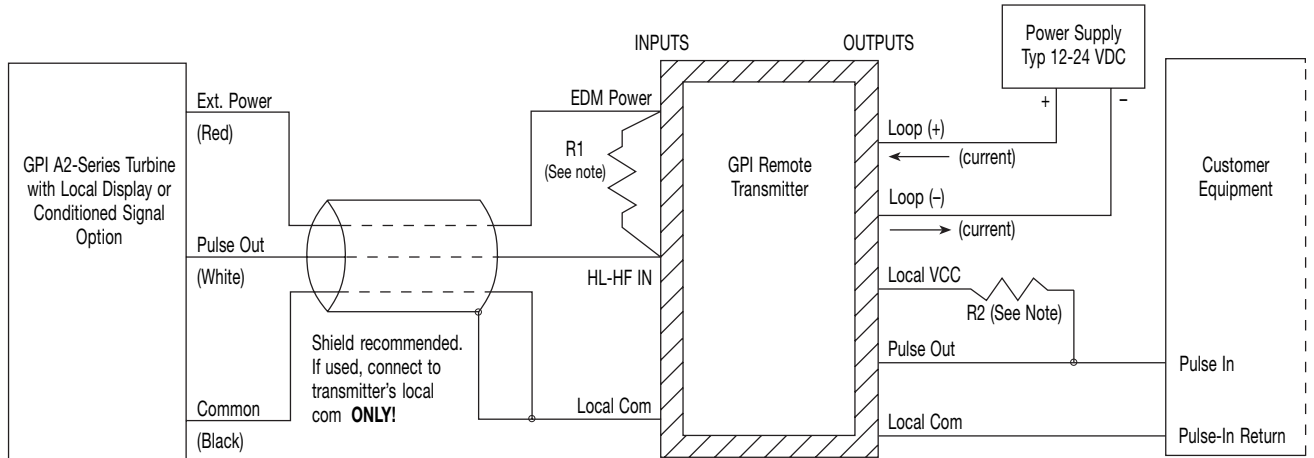

Note Regarding Input Pull-Up Resistor "R1":
 R1 not generally required for distance up to 25 ft.
 Use R1 = 10k (10000 ohms) for distance up to 50 ft.
 Use R1 = 5.1k (5100 ohms) for distance up to 100 ft.
 Use R1 = 2.7k (2700 ohms) for distance up to 250 ft.
 Do not use R1 less than 2.4k (ohms)

Additional Notes:
 Loop power supply electrically isolated from customer equipment.
 Actual value of loop current (mA) is disregarded.
 Output pull-up resistor R2 only required if customer equipment has no internal pull-up resistor on pulse-in input. Typical value 5,000 to 10,000 ohms.

WIRING DIAGRAM 2

**— GPI A2-Series Turbine with Remote-Sensor Option —
Customer Equipment with Frequency Sensing and Separate Loop Power Supply**

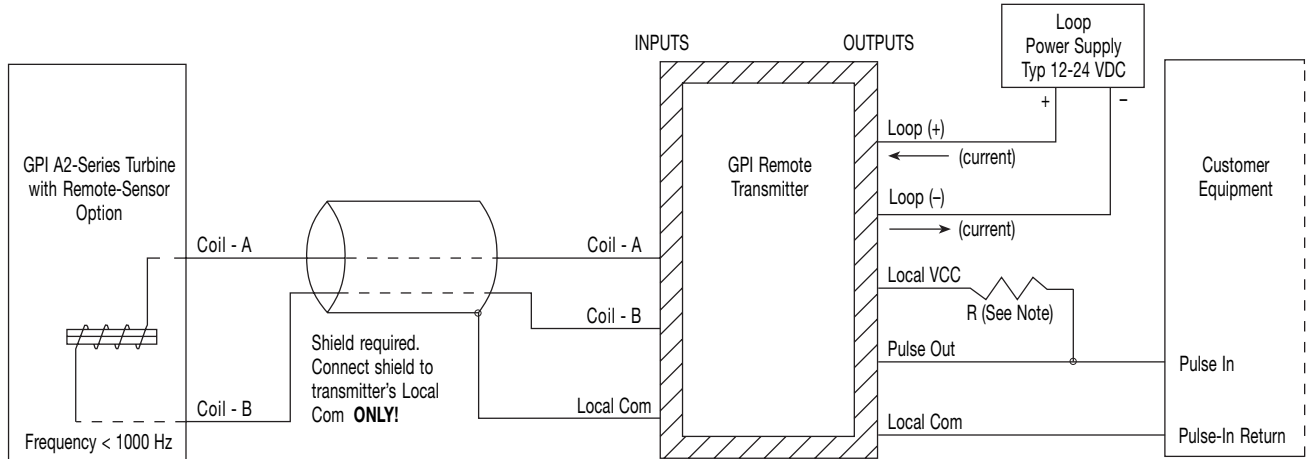

Notes: Minimum signal amplitude required for normal operation approx. 15 mV P-P.
 Recommended cable type - twisted pair with shield.
 Recommended maximum cable length - 20 ft.
 Loop power supply electrically isolated from customer equipment.
 Actual value of loop current (mA) is disregarded.
 Output pull-up resistor R only required if customer equipment has no internal pull-up resistor on pulse-in input. Typical value 5,000 to 10,000 ohms..

OPERATIONS

Display Operations

All operations are reflected in the LCD readout. The top line identifies the calibration curve. The middle line reflects flow information. The bottom line shows information from the totalizer. Words or "flags" display on the top and bottom line to further identify specific information.

Turn On

The meter is on when any display is present. It turns on automatically when liquid flows through the meter. It can be turned on manually by pressing and releasing the DISPLAY button.

Turn Off

The meter turns off automatically approximately four minutes after flow stops. When the meter is off, the readout is blank.

Batch and Cumulative Totals

Total flags are displayed on the bottom line. A Batch Total indicates flow during a single use. It is labeled with TOTAL followed by a number. On most models this is TOTAL 2.

To zero a batch total, make sure it is displayed and hold down DISPLAY for three seconds until the display changes to zeros.

The Cumulative Total (TOTAL 1 on most models) is the total of all liquid measured since the meter's power was connected. The Cumulative Total is labeled as TOTAL LOCKED indicating it cannot be manually zeroed. (See Remote Display 1) The Cumulative Total is zeroed only when power is disconnected or when the Cumulative Total reaches the maximum value of 999,999.

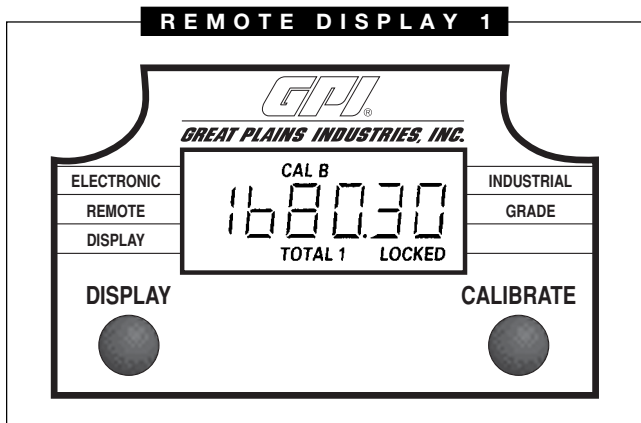

To change between totals, press and release DISPLAY.

NOTE: Generally, readout displays change when buttons are released.

Factory and Field Calibration Curves

Calibration Curve information is shown on the top line of the readout. The Field Calibration Curve is set by the user. It can be changed or modified at any time using the Calibration Procedures in the Calibration Section. If a Field Calibration has not been completed, the meter uses the Factory Calibration Curve. Field Calibration is shown as CAL followed by a letter. On most models this is CAL B.

A Factory Calibration Curve is preset by the manufacturer and stored permanently in the remote's computer. The Factory Calibration Curve is always flagged with PRESET on the top line. In most models, Factory Calibration appears as CAL A PRESET. (See Remote Display 2)

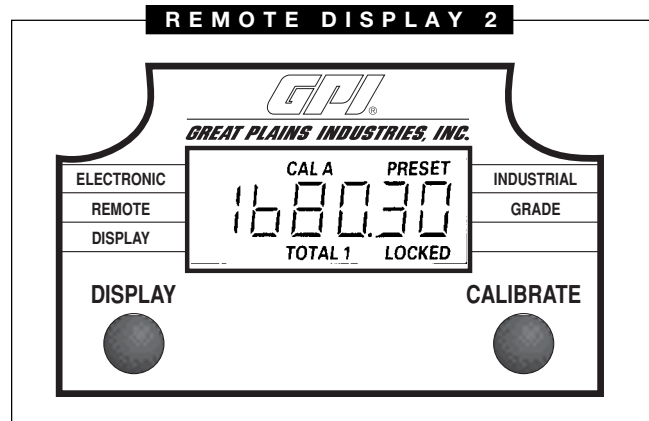

To change between a Field Calibration Curve and a Factory Calibration Curve, hold CALIBRATE down while pressing and releasing DISPLAY. When the desired curve appears, release both buttons.

Flowrate

When this feature is activated, the word FLOWRATE displays to the left on the bottom line. (See Remote Display 3) When this flag is displayed, the numbers on the middle line reflect the rate of flow. To activate this feature, press and release DISPLAY until FLOWRATE appears to the left on the bottom line.

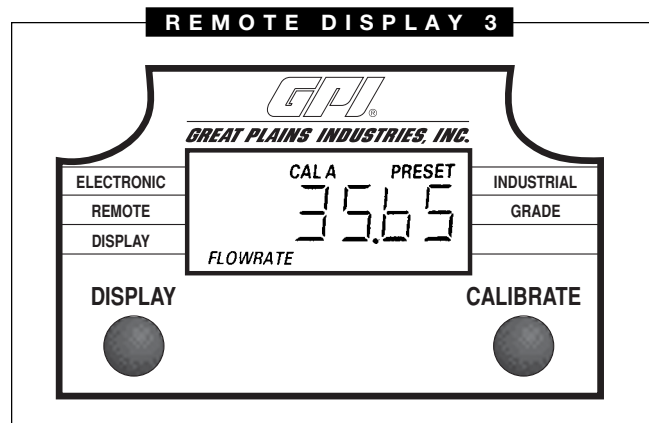

Bypass

Some models contain a Bypass feature for those instances when the meter has continuous flow and power conservation is important. When Bypass is activated the flow is not monitored or totaled by the computer. When activated, BYPASS displays on the middle line. (See Remote Display 4) In Bypass Mode, the meter no longer senses the flow and the readout goes off after a few minutes. Push the DISPLAY button to activate the readout again.

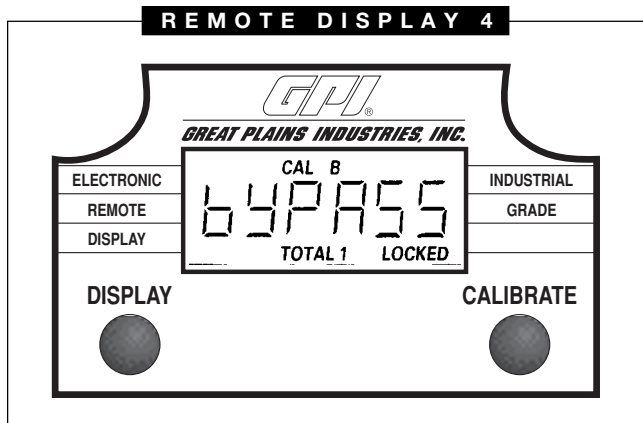

Propeller

A small propeller displays to indicate liquid is flowing through the meter.

“NO” Flag

The NO flag displays on the left of the top line when particular conditions have not been met during calibration procedures. While NO displays, normal flow does not register on the meter. To resume normal flow counting, return to CAL A PRESET and back to CAL B before continuing field calibration.

Display Calibration

NOTE: When power is disconnected or fails, the Batch and Cumulative Totals return to zero. Factory and Field Calibration Curves are retained in the meter’s computer when power is lost.

Field Calibration and Factory calibration are defined in the section above. Field Calibration is necessary when Factory Calibration accuracy is not acceptable. Factory Calibration has been completed with test solvent (on Mid-Flow turbine sizes) or water (on High-Flow turbine sizes) at 70°F (21°C).

If you are dispensing a comparable liquid which has a different uniform viscosity, a Field Calibration can improve meter accuracy.

NOTE: A Field Calibration below the 10:1 flow range can adversely effect accuracy.

The use of a uniformly dependable, accurate calibration container is highly recommended for the most accurate results.

Due to high flowrate, it is strongly recommended that Field Calibration of High Flow (1-1/2 and 2 inch) meters be completed with a combination of volume and weight using fine resolution scales.

For most accurate results during Field Calibration, dispense at a flowrate which best simulates your actual operating conditions. During Field Calibration, avoid repeated stopping or “trickling” of the flow.

Make sure you meet the meter’s minimum flowrate requirements.

- 1/2 inch meters – 1 GPM (3.8 LPM)
- 3/4 inch meters – 2 GPM (7.6 LPM)
- 1 inch meters – 5 GPM (18.9 LPM)
- 1-1/2 inch meters – 10 GPM (38 LPM)
- 2 inch meters – 20 GPM (76 LPM)
- 2-1/2 inch meters – 20 GPM (76 LPM)

If the minimum flowrate requirements are not met during the Field Calibration procedures, the readout blinks “NO” when you try to exit Calibration Mode and you must calibrate again.

The maximum volume dispensed and adjusted during the Calibration Procedure below should not exceed 99.99 units in most models. On models with 1-1/2 or 2-inch fittings and some special order models, the maximum volume should not exceed 999.9 units. During calibration, the two left-hand digits on the readout are ignored.

For best results, the meter should be installed and purged of air prior to Field Calibration.

Dispense/Display Field Calibration Procedures

1. Select a Field Calibration Curve if necessary. Hold down CALIBRATE while pressing and releasing DISPLAY until the Field Calibration Curve appears. Release both buttons.

NOTE: Remember, Field Calibration curves are *not* PRESET.

2. Select a Batch Total if necessary: Press and release DISPLAY until the Batch Total appears.

NOTE: Remember, a Batch Total is *not* LOCKED.

3. Zero the Batch Total: Hold down DISPLAY for three seconds to zero the total.

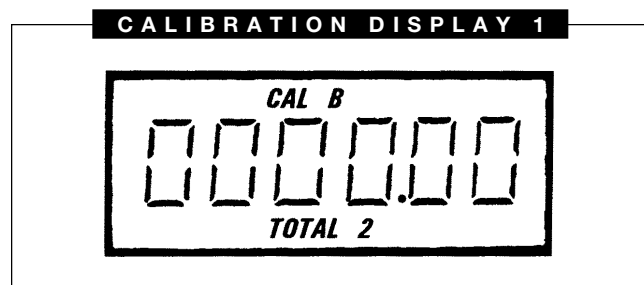

4. Dispense the desired volume and stop.

NOTE: For the most accurate results, dispense at a flowrate which best simulates your actual operating conditions. Avoid stopping or “trickling” the flow.

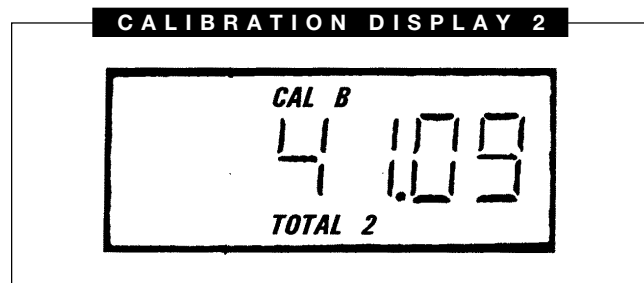

5. Press CALIBRATE then hold down DISPLAY (both) for approximately three seconds until CAL-dd flashes. Release both buttons.

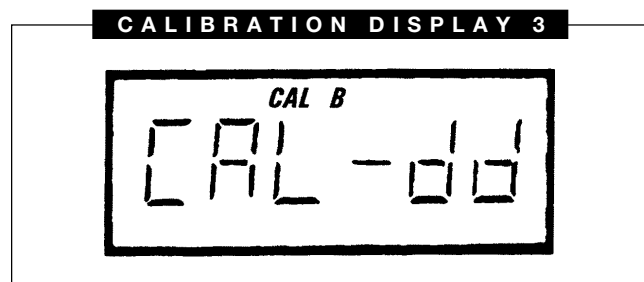

6. When the buttons are released, the volume dispensed returns with one digit flashing. Set this readout to the amount you want. DISPLAY moves from left to right. CALIBRATE changes the value from 0-9.

NOTE: Remember, the two left-hand digits are shown blank and ignored during calibration.

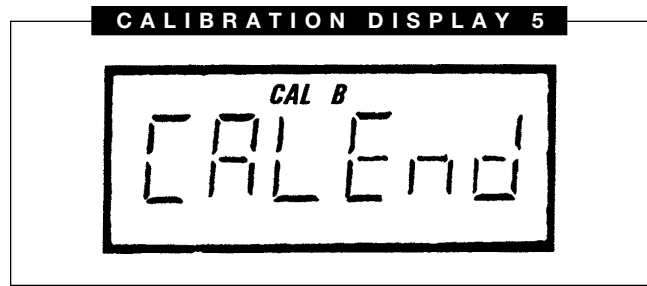
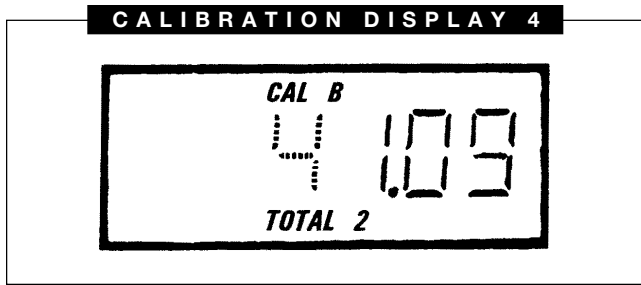

7. With the readout set to the desired amount, hold down CALIBRATE as you briefly press DISPLAY. CAL End flashes and the original amount appears without any flashing digits.

NOTE: Calibration is complete and you can resume normal operations. If NO displays, refer to the Troubleshooting section.

MAINTENANCE

Check cable-entry seals periodically. Tighten and/or apply sealant if needed. This is especially important in environments containing heavy concentrations of dust, oil mist, or other residue.

Check all wiring connections occasionally for oxidation or corrosion. Clean and re-seat if such conditions are noted.

If necessary, check and re-seat any connections that may have been subjected to strain (during rework or construction, for example).

TROUBLESHOOTING

SYMPTOM	PROBABLE CAUSE	CORRECTIVE ACTION
A. METER IS NOT ACCURATE	1. Field Calibration not performed properly.	Field Calibrate again or select Factory Calibration.
	2. Factory Calibration not suitable for liquid being measured.	Perform a Field Calibration according to Calibration Section.
	3. Improper installation of flow-meter.	Check for electrical noise, pulsation or swirl in the flow.
	4. Flowrates too high or too low.	See section on display calibration for flowrates.
B. READOUT FADED OR BLANK	1. Power not connected.	Check power supply.
	2. Computer defective.	Contact the factory.
	3. Temperature limits exceeded.	Check temperature specifications.
C. NORMAL FLOW RATE BUT METER DOES NOT COUNT (Meter comes on when DISPLAY button pushed)	1. Field Calibration not performed correctly.	Field Calibrate again or select Factory Calibration.
	2. Computer defective.	Contact the factory.
	3. Loose wire or mis-wired.	Check wiring diagram.
	4. Sensor not attached to turbine.	Check continuity of sensor.
	5. Faulty sensor.	Contact the factory.

TROUBLESHOOTING

SYMPTOM	PROBABLE CAUSE	CORRECTIVE ACTION
D. CANNOT GET METER INTO FIELD CALIBRATION	1. Factory Calibration (PRESET) curve active.	Hold down CALIBRATE and push and release DISPLAY until PRESET flag goes off. Proceed with calibration according to the Calibration Section.
	2. Computer circuit board defective.	Replace computer. Contact the factory.
	3. Wrong button sequence.	Recalibrate.
	4. Not holding button long enough or hard enough.	Hold button until the appropriate response appears in the display.
	5. Button defective.	Replace computer. Contact the factory.
E. COMPUTER BLINKS "NO" AFTER FIELD CALIBRATION	1. Flowrate too low.	Try again and increase flowrate to minimum calibration rate. See Calibration Section.
	2. Flowrate too high.	Maximum flowrate is usually 10:1 turndown or 10x minimum flowrate.
	3. Rotor not spinning freely.	Remove meter. Clean carefully. Make sure rotor spins freely.
	4. Volume too low.	See section on display calibration for minimums.
	5. Loose wiring.	Check wiring.
	6. Faulty sensor.	Contact the factory.
F. PULSE-OUT OUTPUT DOESN'T WORK	1. No pull-up resistor or pull-up power.	Be sure pull-up resistor and pull-up power present, with correct polarity.

DIMENSIONS

PIPE MOUNT DIMENSIONS

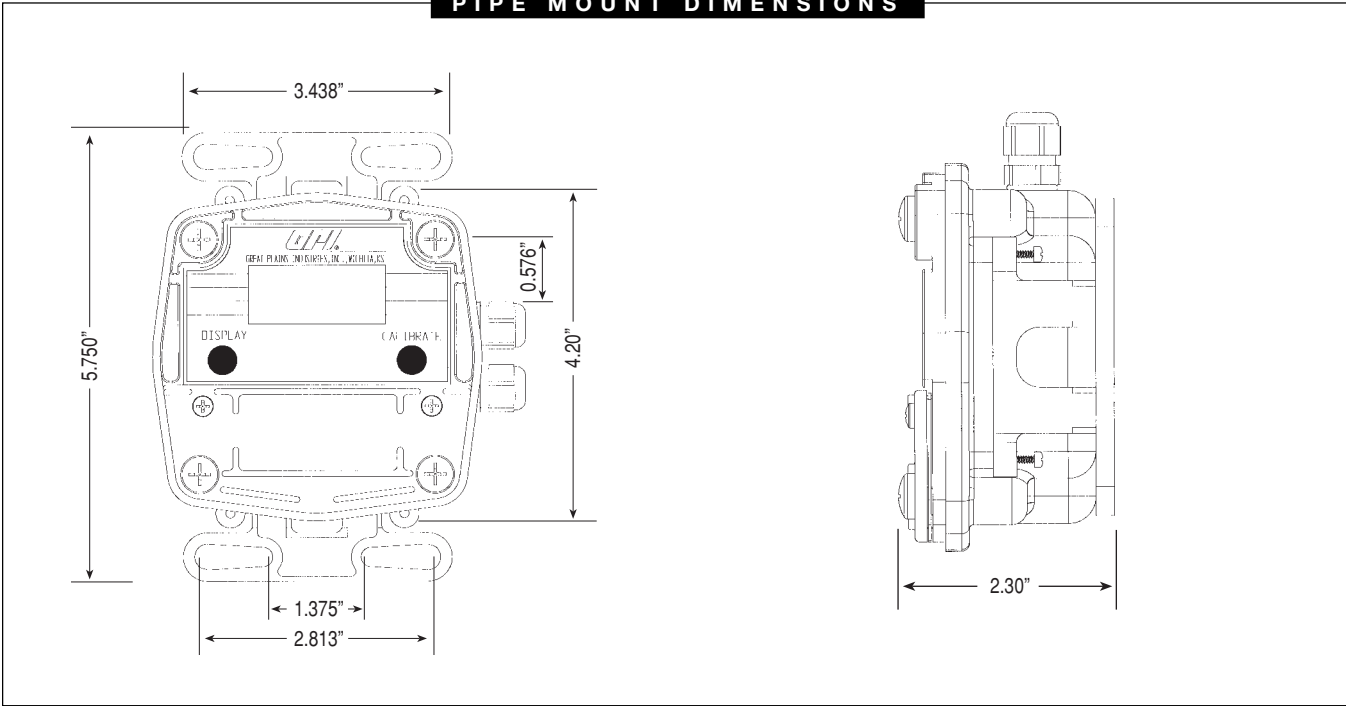

WALL MOUNT DIMENSIONS

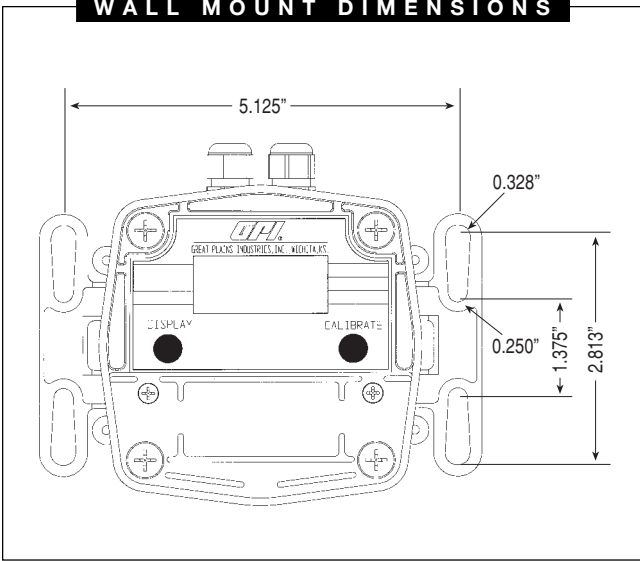

PANEL CUT-OUT DIMENSIONS

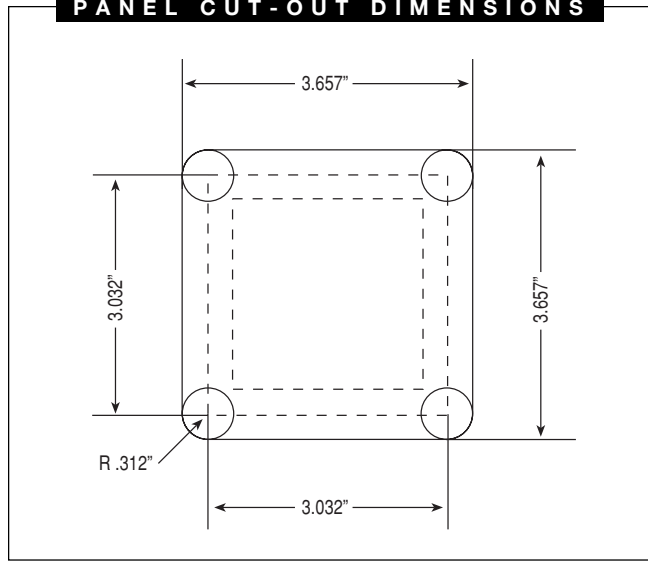

SPECIFICATIONS

Mechanical:

Enclosure:	Equiv. to NEMA 4/IP65
Strain Relief:	Hubble PG7 Grip range 0.11-0.26
Strain Relief Thread:	Female 1/2-20 UNF-2B
Cable:	Belden 9363 (22AWG-2 conductor w/drain wire and shield)
Cable Length:	20 ft (6m) provided
Operation Temperature:	+14°F to 140°F (-10°C to 60°C)
Storage Temperature (with display):	-40°F to 158°F (-40°C to 70°C)

Power Supply:

Voltage Requirement:	
Minimum:	8.5 VDC
Maximum:	35 VDC (higher voltage may damage unit)

Primary Output:

Pulse-Out

Type:	Open collector NPN (current sinking)
Max. "OFF" voltage:	60 V
Max. "ON" current:	200 mA
Max. "ON" voltage drop:	< 0.5V @ 200mA

Auxiliary Outputs:

EDM-Pwr

Type:	Can supply regulated 5 VDC at up to 1.5mA to external circuitry
-------	---

Sensor Options

(For use with GPI A2 Turbine Meters)

Turbine Mounted Display Option:

Output Type:	Open Collector
Display Type:	Both Local and Remote Display
Sensor to Transmitter Distance:	Up to 25 ft. as supplied. Can reach up to 250 ft. with addition of customer-supplied pull-up resistor.

Conditioned Signal Sensor Option:

Output Type:	Open Collector
Display Type:	Remote Display Only
Sensor to Transmitter Distance:	Up to 25 ft. as supplied. Can reach up to 250 ft. with addition of customer-supplied pull-up resistor.

Standard Remote Sensor Option:

Output Type:	Low Level Sine Wave
Display Type:	Remote Display with Low or High Temperature liquids -40°F to 250°F (-40°C to 121°C)
Sensor to Transmitter Distance:	Up to 20 ft.

Frequency Inputs (Remote Display):

Low Level Coil (LLC):	Frequency Range 0-1000 Hz (waveform dependent)
High-Level Low Frequency (HLLF):	Frequency Range 0-150 Hz (debounced, waveform dependent)
High Level High Frequency (HLHF):	Frequency Range 0-1200 Hz (not debounced, requires clean logic level square or rectangular waveform)
Optically isolated HLLF:	Same as HLLF with 2500 V optical isolation
Optically isolated HLHF:	Same as HLHF with 2500 V optical isolation

NOTE: GPI A2 Turbine Meter Sensors use High Level High Frequency (HLHF) input. For other sensor types, call GPI Customer Support for technical specifications.

PARTS LIST

Part No.	Description
120048-01	Gasket
120058-01	Bracket
120509-01	Adapter Kit
120510-01	Circuit Kit (Main)
120511-01	Computer Kit
120512-01	Optional Add-on 4-20 Board
120513-01	Strain Relief Kit
125066-3	Cable, 100 feet
125066-20	Cable, 20 feet
901002-82	O-Ring
904005-27	Sems Screw and Washer (2 ea. required)
904005-28	Sealing Screw (4 ea. required)

SERVICE

For warranty consideration, parts, or other service information, please contact your local distributor. If you need further assistance, contact the GPI Customer Service Department in Wichita, Kansas, during normal business hours.

Tel: 316-686-7361
Fax: 316-686-6746

To obtain prompt, efficient service, always be prepared with the following information:

- The model number
- The manufacturing date code

The date code is a four-digit number (XXXX) located under the coverplate.

For warranty work, always be prepared with your original sales slip or other evidence of purchase date.

Please contact GPI before returning any part. It may be possible to diagnose the trouble and find a solution with a telephone call. GPI can also inform you of any special requirements you will need to follow for shipping.

SAVE THESE INSTRUCTIONS

Limited Warranty Policy

Great Plains Industries, Inc. 5252 E. 36th Street North, Wichita, KS USA 67220-3205, hereby provides a limited **one year warranty** against defects in material and workmanship on all products manufactured by Great Plains Industries, Inc. except models BP-10, BP-12, LP-50, RP-5 and CP-5. These models carry a 90-day warranty. The warranty shall extend to the purchaser of this product and to any person to whom such product is transferred during the warranty period.

The warranty period shall begin on the date of the original new equipment purchase. Warrantor's obligation hereunder shall be limited to repairing defective workmanship or replacing or repairing any defective part or parts. This warranty shall not apply if:

- A. the product has been altered or modified outside the warrantor's duly appointed representative;
- B. the product has been subjected to neglect, misuse, abuse or damage or has been installed or operated other than in accordance with the manufacturer's operating instructions.

To make a claim against this warranty, notice of claim must be given in writing to the company at its above address no later than 30 days after the expiration of the warranty period. Such notice shall identify the defect in the product. The company shall, within 14 days of receipt of such notice, notify the customer to either send the product, transportation prepaid, to the company at its office in Wichita, Kansas, or to duly authorized service center. The company shall perform all obligations imposed on it by the terms of this warranty within 60 days of receipt of the defective product.

GREAT PLAINS INDUSTRIES, INC. EXCLUDES LIABILITY UNDER THIS WARRANTY FOR DIRECT, INDIRECT, INCIDENTAL AND CONSEQUENTIAL DAMAGES INCURRED IN THE USE OR LOSS OF USE OF THE PRODUCT WARRANTED HEREUNDER.

The company herewith expressly disclaims any warranty of merchantability or fitness for any particular purpose other than for which it was designed.

This warranty gives you specific rights and you may also have other rights which vary from U.S. state to U.S. state.

Note: In compliance with MAGNUSON MOSS CONSUMER WARRANTY ACT – Part 702 (governs the resale availability of the warranty terms).



5252 East 36th Street North
Wichita, KS USA 67220-3205
TEL: 316-686-7361
FAX: 316-686-6746

GREAT PLAINS INDUSTRIES, INC.

"A Great Plains Ventures Subsidiary"

www.gpi.net

1-888-996-3837