

SAVE THESE INSTRUCTIONS



5252 East 36th Street North
Wichita, KS USA 67220-3205
TEL: 316-686-7361
FAX: 316-686-6746

GREAT PLAINS INDUSTRIES, INC.

"A Great Plains Ventures Subsidiary"

www.gpi.net

1-888-996-3837

Industrial Grade Remote 4-20mA Transmitter with Display

Owner's Manual

Manual No. 920765-01 Rev. A

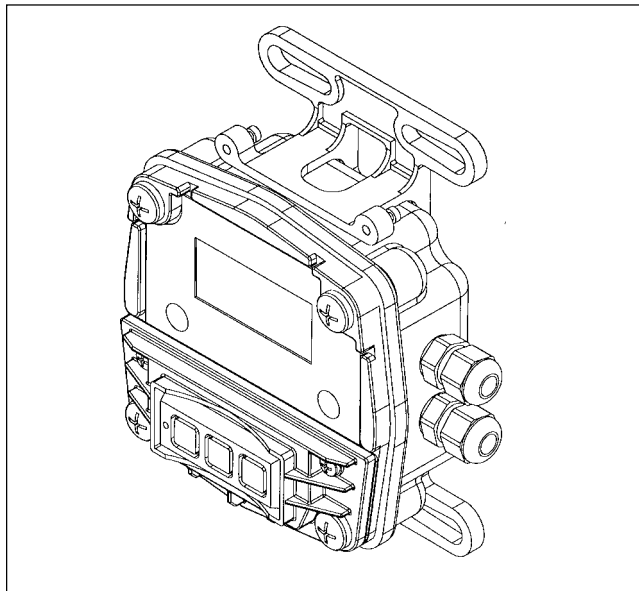

To the owner...

Congratulations on receiving your GPI Remote Transmitter. We are pleased to provide you with a product designed to give you maximum reliability and efficiency.

Our business is the design, manufacture, and marketing of liquid handling, agricultural, and recreational products. We succeed because we provide customers with innovative, reliable, safe, timely, and competitively-priced products. We pride ourselves in conducting our business with integrity and professionalism.

We are proud to provide you with a quality product and the support you need to obtain years of safe, dependable service.

President
Great Plains Industries, Inc.

TABLE OF CONTENTS

General Information	1
Product Description	2
Safety Instructions	2
Installation	2
Wiring	3
Operations	6
Maintenance	9
Troubleshooting	10
Dimensions	11
Specifications	12
Parts List	13
Service	13

GENERAL INFORMATION

This manual will assist you in operating and maintaining the computer electronics of the GPI Remote Transmitter. Included in this manual is information on calibrating the transmitter display and 4-20mA output.

This manual is for use with GPI A2 Series Turbine Meters only (Models 050, 075, 100, 150, 200, and 250 in stainless steel, PVC, PVDF, brass, and aluminum).

The Remote Transmitter can be configured to provide Remote Display (using *Conditioned Signal Sensor* or *Standard Remote* options) or Local and Remote Display (using Turbine Mounted Display option). Details on using the transmitter with other meters can be obtained from GPI customer service.

PRODUCT DESCRIPTION

The GPI Remote Transmitter is a flow totalizer and rate meter with industry standard current loop output. The Remote Transmitter accepts input pulses from a turbine meter or other frequency generating meter, and uses those pulses to calculate the flow total and rate in a pipeline. The unit is loop powered, and provides a 4-20mA analog output proportional to the frequency signal for communication with PLCs and other customer equipment. The 4-20mA (or 0-20mA) output is calibrated under actual flow conditions with simple push-button calibration. Auxiliary output includes 0-5 VDC and pulse output. The transmitter can be pipe, wall, or panel mounted.

The microprocessor-based electronics have extremely low power requirements and are completely powered by the 4-20 loop. The electronics provides the options of local (on the meter) and/or remote (up to 5,000 feet) display. Flow total and rate are displayed on a large 6-digit LCD readout with two-point floating decimal for totals from .01 to 999,999. All operations are easily accessed with the push buttons on the display front panel.

⚠ CAUTION

This transmitter is not yet FM Approved. Therefore, use of this transmitter with an approved metering system voids FM Approval.

NOTE: This transmitter is loop powered, requiring an input power supply of 8.5 to 35 volts (24 VDC is recommended).

NOTE: Setpoint calibration of the transmitter is required for the 4-20mA, 0-20mA, and 0-5 V output options.

SAFETY INSTRUCTIONS

- When measuring flammable liquids, observe precautions against fire or explosion.
- When working in hazardous environments, always exercise appropriate safety precautions.
- When applying external power to the transmitter, use DC power only.
- Disconnect external power to the transmitter before detaching or attaching input or output wires.
- Ground loops between sensor and user equipment can damage the transmitter and can be dangerous.
- If you cannot galvanically isolate the sensor from earth ground, you may need to use the transmitter's optically isolated inputs.
- Be sure O-rings and seals are kept in good repair.

INSTALLATION

⚠ CAUTION

Installation should be performed only by qualified personnel, and in accordance with local governing regulations.

Environmental

Choose a mounting location suitable for the remote transmitter. The ideal mounting location is where the:

- turbine meter is as close as possible.
- mounting surface has minimal vibration.
- ambient temperature is +30°F to 140°F (0°C to 60°C) when using remote display.
- cable lengths are minimal.

Avoid mounting locations where the remote transmitter is:

- subject to constant exposure to water or other liquids (occasional low-pressure splashing will not harm unit if cable entry points are well-sealed).
- subject to > 5g shock loading.
- facing the sun directly for long periods of time.
- close to high voltage/current runs, DC motors, internal combustion engines, or frequency inverters.

Cable Guidelines

4-20mA Current Loop:

- The current loop itself is very resistant to electrical noise pickup and shielded cable is seldom needed except in very "noisy" (electrical) locations and/or when very long runs (thousands of feet) are used.

Sensor Cabling:

- GPI A2 Turbine Sensors are sold as part of the Remote Transmitter and come with 20 ft. of shielded cable.
- If you require a longer cable, a 100 ft. cable kit is available from GPI, or use Belden 9363 cable. When wiring longer lengths of cable, be sure to connect the shield to transmitter LOCAL-COM ONLY! (Multiple shield connections may cause ground-loop problems).
- Some trial and error may be needed because of the wide variety of user conditions. Try to keep cable lengths short!

WIRING

If you ordered your Remote Transmitter to use with a GPI A2 Industrial Meter, the transmitter comes with 20 ft. of cable to connect to the meter. The customer must supply the communication loop cable. Although the transmitter is usually powered through the communication loop, there are some circumstances that might require external power.

Connecting the Equipment:

- Remove the faceplate by removing the four (4) corner screws.
- Attach wiring from your equipment according to the following terminal connections and wiring diagrams, depending on your circumstances.

Terminal Connections Remote Transmitter INPUTS / OUTPUTS

ISO-IN COM: Return for isolated inputs

ISO-LF IN: Optically-Isolated High-level Low-frequency Input

ISO-HF IN: Optically-Isolated High-level High-frequency Input

HL-LF IN: High-level Low-frequency Input. 150 Hz maximum

COIL-A IN: Low-level Sinewave Input

COIL-B IN: Low-level Sinewave Input

HL-HF IN: High-level High-frequency Input

EDM PWR: Local Vcc. Regulated 5-VDC internal power. This terminal can supply up to approximately 2.5 mA, continuously, to external circuitry. Typical load/line regulation under ordinary conditions is about $\pm 10\%$

LOCAL COM: Local Common

0-5 V OUT: 0 to 5 V Voltage Output. Frequency to Analog Output.

PULSE OUT: Pulse-Out Frequency Output Signal. It is an "open-collector" output (also known as "n-p-n" or "current-sinking"), referenced to transmitter Local-Common

LOOP (-): 4 to 20 mA Current Loop – current into transmitter

LOOP (+): 4 to 20 mA Current Loop – current out of transmitter

WIRING DIAGRAM 1

— 4-20mA or 0-20mA Output —

Customer Equipment with Built-in Power Supply

Input: Turbine Mounted Display or Conditioned Signal Sensor (Open Collector)
Output: Customer Equipment, 0-20mA Sensing, Built-in Loop Power Supply

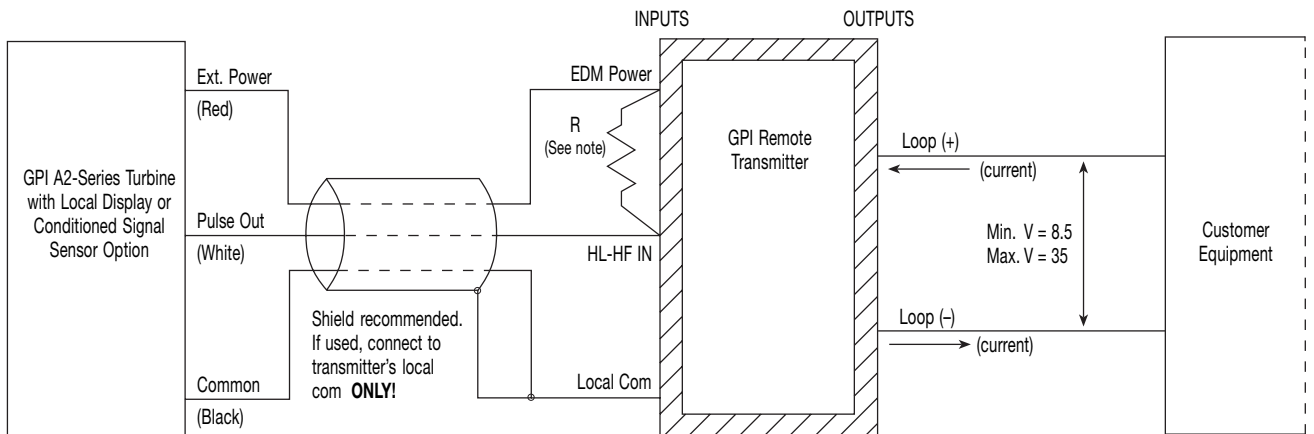

Note Regarding Resistor "R": R not generally required for distance up to 25 ft.
Use R = 10k (10000 ohms) for distance up to 50 ft.
Use R = 5.1k (5100 ohms) for distance up to 100 ft.
Use R = 2.7k (2700 ohms) for distance up to 250 ft.
Do not use R less than 2.4k (ohms)

CAUTION: When reassembling the faceplate, make sure that the enclosure seal is not crimped or twisted. Do not over-tighten corner screws (hand tighten only). Faceplate can be rotated 90°.

WIRING DIAGRAM 2

— 4-20mA or 0-20mA Output —

Customer Equipment With Built-in Power Supply - High Temp Applications

Input: Standard Remote Sensor (Variable Reluctance Pickup Coil)

Output: Customer Equipment, 0-20mA Sensing, Built-in Loop Power Supply

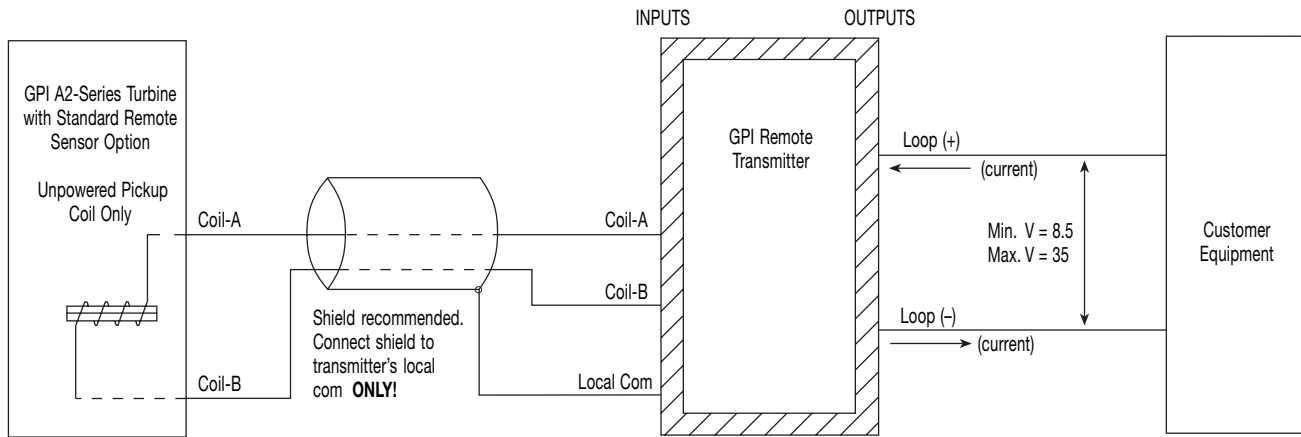

- ▶ Minimum signal amplitude required for normal operation approx. 15 mV P-P
- ▶ Recommended cable type - twisted pair with shield
- ▶ Recommended maximum cable length - 20 ft.

CAUTION: When reassembling the faceplate, make sure that the enclosure seal is not crimped or twisted. Do not over-tighten corner screws (hand tighten only). Faceplate can be rotated 90°.

WIRING DIAGRAM 3

— 4-20mA or 0-20mA Output —

Customer Equipment Without Built-in Power Supply

Input: Turbine Mounted Display or Conditioned Signal Sensor (See inputs from Diagram 1) Standard Remote Sensor (See inputs from Diagram 2)

Output: Customer Equipment, 0-20mA Sensing, Separate Power Supply

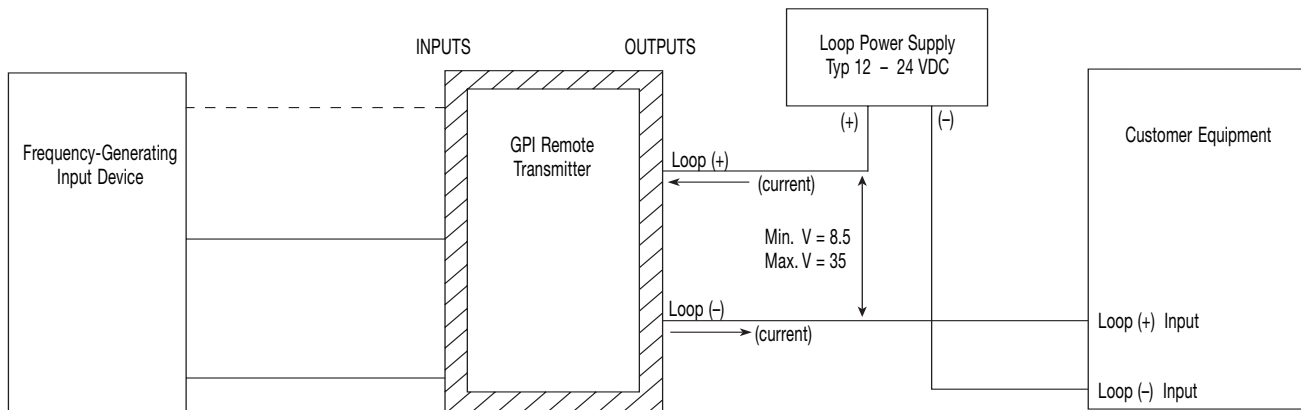

NOTE: Minimum loop power supply voltage required:
 $8.5V + (\text{Max} - \text{Customer} - \text{Equipment} - \text{Drop}) + (\text{Wiring} - \text{IR} - \text{Drop})$

CAUTION: When reassembling the faceplate, make sure that the enclosure seal is not crimped or twisted. Do not over-tighten corner screws (hand tighten only). Faceplate can be rotated 90°.

WIRING DIAGRAM 4

— 0-5 V Output —

Customer Equipment Without Built-in Power Supply

Input: Turbine Mounted Display or Conditioned Signal Sensor (See inputs from Diagram 1) Standard Remote Sensor (See inputs from Diagram 2)
 Output: Customer Equipment, 0-5 V Sensing, Separate Loop Power Supply

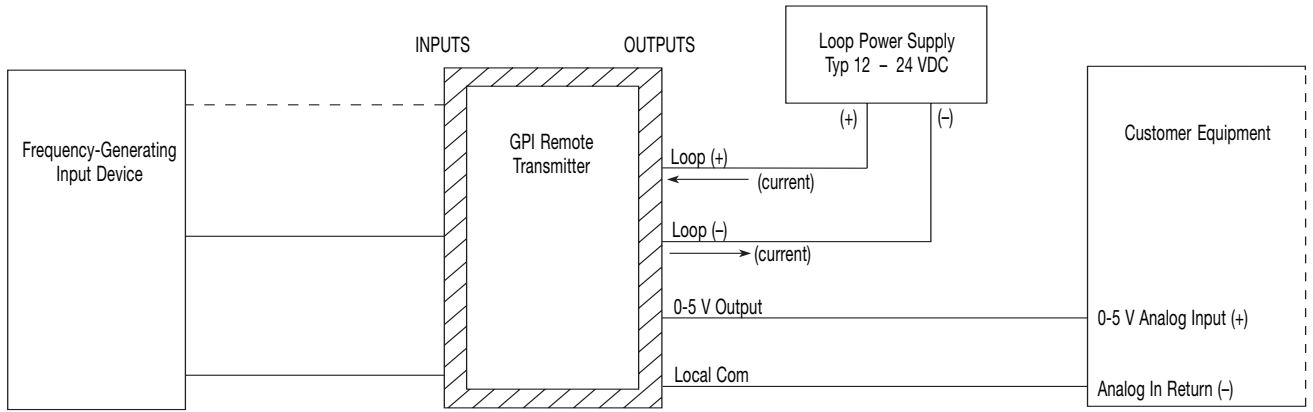

NOTE 1: Loop power supply electrically isolated from customer equipment
 NOTE 2: Actual value of loop current (mA) is disregarded

CAUTION: When reassembling the faceplate, make sure that the enclosure seal is not crimped or twisted. Do not over-tighten corner screws (hand tighten only). Faceplate can be rotated 90°.

WIRING DIAGRAM 5

— Pulse Output —

Customer Equipment Without Built-in Power Supply

Input: Turbine Mounted Display or Conditioned Signal Sensor (See inputs from Diagram 1) Standard Remote Sensor (See inputs from Diagram 2)
 Output: Customer Equipment, Frequency Sensing, Separate Loop Power Supply

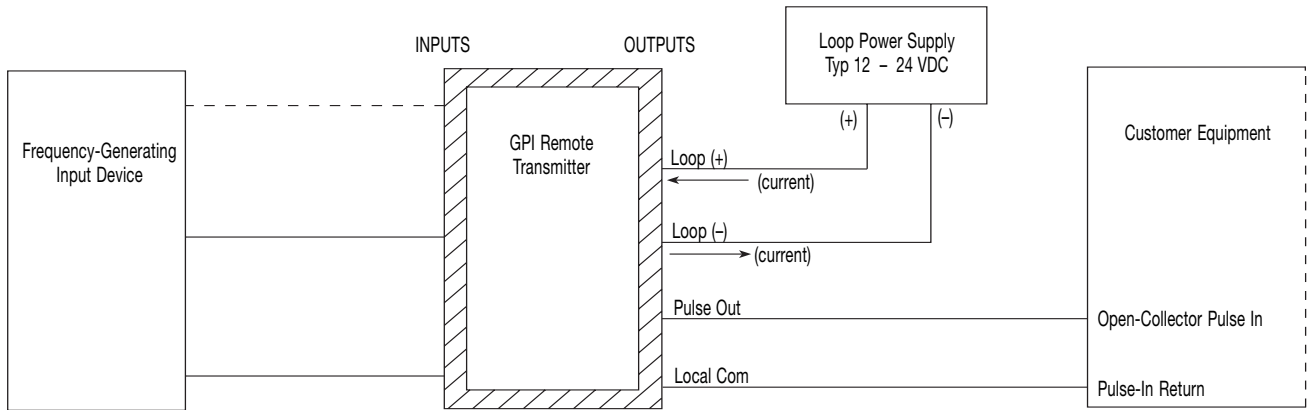

NOTE 1: Loop power supply electrically isolated from customer equipment
 NOTE 2: Actual value of loop current (mA) is disregarded

CAUTION: When reassembling the faceplate, make sure that the enclosure seal is not crimped or twisted. Do not over-tighten corner screws (hand tighten only). Faceplate can be rotated 90°.

OPERATIONS

Display Operations

All operations are reflected in the LCD readout. The top line identifies the calibration curve. The middle line reflects flow information. The bottom line shows information from the totalizer. Words or "flags" display on the top and bottom line to further identify specific information.

Turn On

The meter is on when any display is present. It turns on automatically when liquid flows through the meter. It can be turned on manually by pressing and releasing the DISPLAY button.

Turn Off

The meter turns off automatically approximately four minutes after flow stops. When the meter is off, the readout is blank.

Batch and Cumulative Totals

Total flags are displayed on the bottom line. A Batch Total indicates flow during a single use. It is labeled with TOTAL followed by a number. On most models this is TOTAL 2.

To zero a batch total, make sure it is displayed and hold down DISPLAY for three seconds until the display changes to zeros.

The Cumulative Total (TOTAL 1 on most models) is the total of all liquid measured since the meter's power was connected. The Cumulative Total is labeled as TOTAL LOCKED indicating it cannot be manually zeroed. (See Remote Display 1) The Cumulative Total is zeroed only when power is disconnected or when the Cumulative Total reaches the maximum value of 999,999.

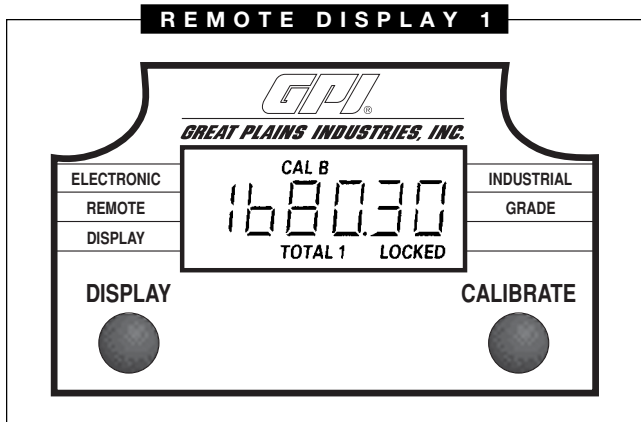

To change between totals, press and release DISPLAY.

NOTE: Generally, readout displays change when buttons are released.

Factory and Field Calibration Curves

Calibration Curve information is shown on the top line of the readout. The Field Calibration Curve is set by the user. It can be changed or modified at any time using the Calibration Procedures in the Calibration Section. If a Field Calibration has not been completed, the meter uses the Factory Calibration Curve. Field Calibration is shown as CAL followed by a letter. On most models this is CAL B.

A Factory Calibration Curve is preset by the manufacturer and stored permanently in the remote's computer. The Factory Calibration Curve is always flagged with PRESET on the top line. In most models, Factory Calibration appears as CAL A PRESET. (See Remote Display 2)

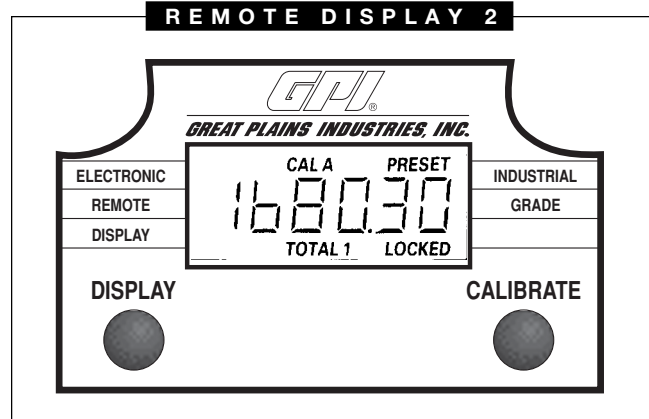

To change between a Field Calibration Curve and a Factory Calibration Curve, hold CALIBRATE down while pressing and releasing DISPLAY. When the desired curve appears, release both buttons.

Flow Rate

When this feature is activated, the word FLOWRATE displays to the left on the bottom line. (See Remote Display 3) When this flag is displayed, the numbers on the middle line reflect the rate of flow. To activate this feature, press and release DISPLAY until FLOWRATE appears to the left on the bottom line.

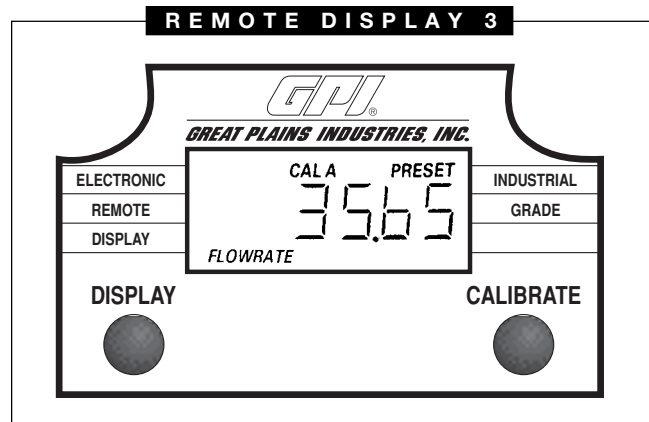

Bypass

Some models contain a Bypass feature for those instances when the meter has continuous flow and power conservation is important. When Bypass is activated the flow is not monitored or totaled by the computer. When activated, BYPASS displays on the middle line. (See Remote Display 4) In Bypass Mode, the meter no longer senses the flow and the readout goes off after a few minutes. Push the DISPLAY button to activate the readout again.

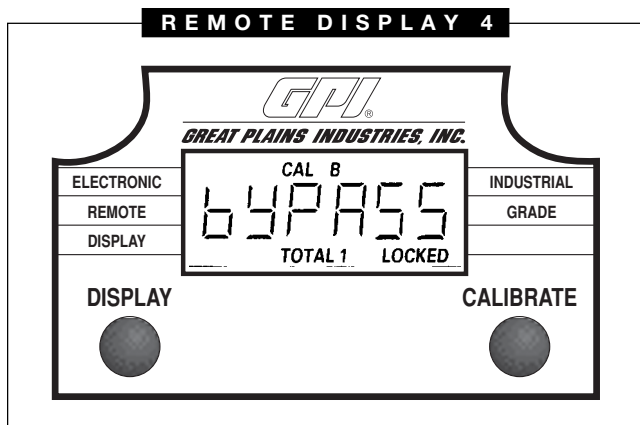

Propeller

A small propeller displays to indicate liquid is flowing through the meter.

“NO” Flag

The NO flag displays on the left of the top line when particular conditions have not been met during calibration procedures. While NO displays, normal flow does not register on the meter. To resume normal flow counting, return to CAL A PRESET and back to CAL B before continuing field calibration.

Display Calibration

NOTE: Calibration of the display is independent of the 4-20mA endpoint calibration.

NOTE: When power is disconnected or fails, the Batch and Cumulative Totals return to zero. Factory and Field Calibration Curves are retained in the meter's computer when power is lost.

Field Calibration and Factory calibration are defined in the section above. Field Calibration is necessary when Factory Calibration accuracy is not acceptable. Factory Calibration has been completed with test solvent (on Mid-Flow turbine sizes) or water (on High-Flow turbine sizes) at 70°F (21°C).

If you are dispensing a comparable liquid which has a different uniform viscosity, a Field Calibration can improve meter accuracy.

NOTE: A Field Calibration below the 10:1 flow range can adversely effect accuracy.

The use of a uniformly dependable, accurate calibration container is highly recommended for the most accurate results.

Due to high flow rate, it is strongly recommended that Field Calibration of High Flow (1-1/2 and 2 inch) meters be completed with a combination of volume and weight using fine resolution scales.

For most accurate results during Field Calibration, dispense at a flow rate which best simulates your actual operating conditions. During Field Calibration, avoid repeated stopping or “trickling” of the flow.

Make sure you meet the meter's minimum flow rate requirements.

- 1/2 inch meters – 1 GPM (3.8 LPM)
- 3/4 inch meters – 2 GPM (7.6 LPM)
- 1 inch meters – 5 GPM (18.9 LPM)
- 1-1/2 inch meters – 10 GPM (38 LPM)
- 2 inch meters – 20 GPM (76 LPM)
- 2-1/2 inch meters – 20 GPM (76 LPM)

If the minimum flow rate requirements are not met during the Field Calibration procedures, the readout blinks “NO” when you try to exit Calibration Mode and you must calibrate again.

The maximum volume dispensed and adjusted during the Calibration Procedure below should not exceed 99.99 units in most models. On models with 1-1/2 or 2-inch fittings and some special order models, the maximum volume should not exceed 999.9 units. During calibration, the two left-hand digits on the readout are ignored.

For best results, the meter should be installed and purged of air prior to Field Calibration.

Dispense/Display Field Calibration Procedures

1. Select a Field Calibration curve if necessary: Hold down CALIBRATE while pressing and releasing DISPLAY until the Field Calibration Curve appears. Release both buttons.

NOTE: Remember, Field Calibration curves are *not* PRESET.

2. Select a Batch Total if necessary: Press and release DISPLAY until the Batch Total appears.

NOTE: Remember, a Batch Total is *not* LOCKED.

3. Zero the Batch Total: Hold down DISPLAY for three seconds to zero the total.

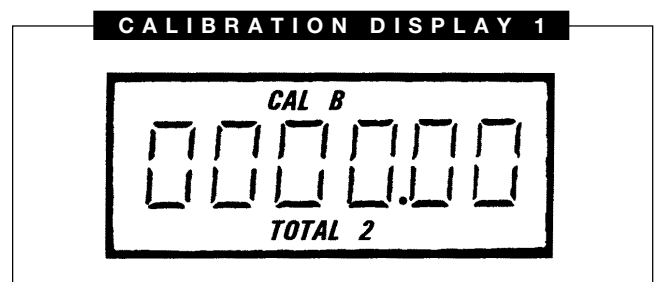

4. Dispense the desired volume and stop.

NOTE: For the most accurate results, dispense at a flow rate which best simulates your actual operating conditions. Avoid stopping or “trickling” the flow.

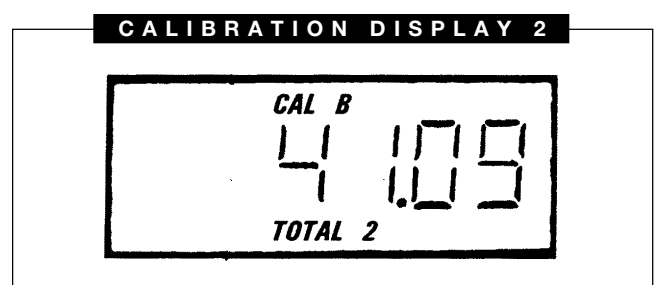

- Press CALIBRATE then hold down DISPLAY (both) for approximately three seconds until CAL-dd flashes. Release both buttons.

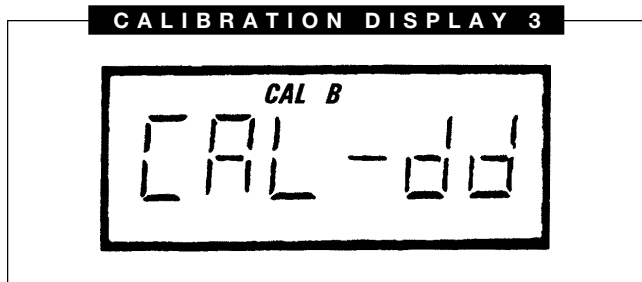

- When the buttons are released, the volume dispensed returns with one digit flashing. Set this readout to the amount you want. DISPLAY moves from left to right. CALIBRATE changes the value from 0-9.

NOTE: Remember, the two left-hand digits are shown blank and ignored during calibration.

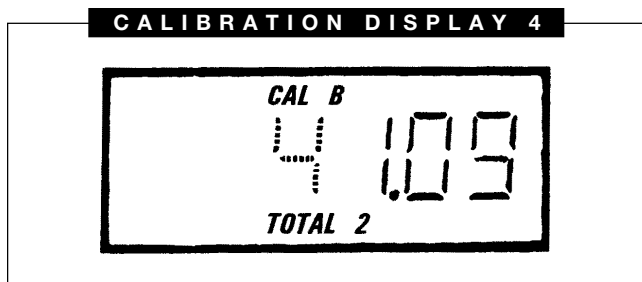

- With the readout set to the desired amount, hold down CALIBRATE as you briefly press DISPLAY. CAL End flashes and the original amount appears without any flashing digits.

NOTE: Calibration is complete and you can resume normal operations. If NO displays, refer to the Troubleshooting section.

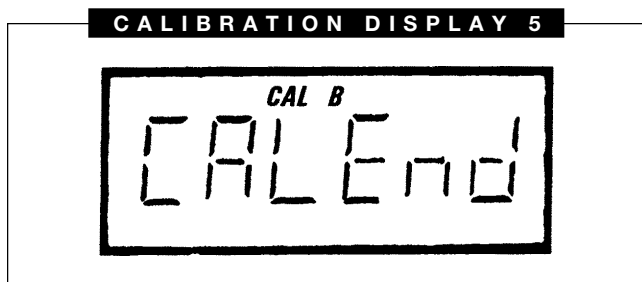

Setting 4-20mA Endpoints

The 4-20mA endpoint settings are independent from the display calibration. If you reset the response time (procedure detailed below) you MUST reset the 4-20mA endpoints.

All units are shipped with the following items preset:

- 4mA setpoint = 50Hz
- 20mA setpoint = 100Hz
- Response Time = 0.7 second

Any new values you set for these items are automatically saved when the transmitter is powered down, and automatically restored the next time power is applied.

Procedure

Before you start, the fluid pumping system should be ready to make two simple calibrating runs, first at the lowest anticipated flowrate, and then the second at the highest anticipated flowrate. For best accuracy, you should include a separate flowrate indicating meter, such as an appropriate GPI model, in the fluid flow path. Position yourself so you can easily operate the transmitter's pushbuttons. You should be able to see the indicator light (the small window beside the "4" button).

Setting the Low (4mA) Endpoint:

- Start the fluid pumping system. Set it for steady flow at the lowest anticipated rate (or the rate at which you want a "minimum" indication).
- Wait while the fluid flow is uninterrupted for at least 10 seconds.
- While watching the transmitter's indicating light, press and hold both its "SET" and "4" buttons. Release them when the light blinks.

NOTE: The length of time between "button press" and "light blink" depends on the transmitter response time. The maximum is 5 seconds. If you can't see the indicator light (if you're outdoors in bright light), you can safely just count to 5 while holding the pushbuttons.

NOTE: After setting the minimum, the loop current should be registering at or near 4mA. Don't worry if it's not exact, it will be correct after setting the high (20mA) endpoint.

Setting the High (20mA) Endpoint

- Start the fluid pumping system. Set it for steady flow at the highest anticipated rate (or the rate at which you want a "maximum" indication).
- Wait while the fluid flow is uninterrupted for at least 10 seconds.

NOTE: If you observe the current loop after completing the procedure, it should be registering at or very near 20mA (within the resolution specifications for the present conditions).

- While watching the transmitter's indicating light, press and hold both its "SET" and "20" buttons. Release them when the light blinks.

NOTE: During the high and low setpoint procedure, if the new settings are very different from the previous settings, it is possible to reverse the 4mA and 20mA setpoints so that the 4mA frequency is **higher** than the 20mA frequency. The situation corrects itself after you complete both setpoints. If the new settings are close to the previous settings, you may safely set either the low and high settings independently.

Optional 0-20mA Mode

A few current loop systems use 0-20mA output. The input signal frequency of “0” produces an output analog signal of “0” with direct proportionality and no offset.

NOTE: A true loop current of “0” in a loop powered device like the GPI transmitter is not obtainable. That’s because the current loop powers the transmitter, and its operating current is non-zero even at zero frequency input. In 0-20 mode, the GPI Remote Transmitter’s loop current will drop to as near zero as possible at zero input, in most units between 1 and 2 mA.

Procedure

1. To enter 0-20 mode, simply press and hold all three pushbuttons simultaneously (4, SET, and 20) at any flow-rate. Continue holding until the indicator light blinks (light will blink in up to 5 seconds) and release all buttons. This sets the LOW END calibration point to zero/zero.
2. Set the 20ma endpoint as described above under 4-20mA calibration.
3. The special 0-20 mode will remain in effect until a new 4mA endpoint is established in the usual way.

Auxiliary 0-5 VDC

The Remote Transmitter is equipped with an auxiliary voltage output with a range of 0-5 VDC. This signal is capable of dropping to within a few millivolts of zero, and thus may be more suitable for use in the 0-20 mode.

No special equipment is required to use the 0-5V output, but wiring to customer equipment is different (see Wiring Diagram 4).

Changing Response Time

The Remote Transmitter comes from the factory with a default 0.7 second response time. This should provide good performance with all GPI A2 meters.

 WARNING
<p>If you reset the response time (procedure detailed below) you MUST then reset the 4-20mA endpoints.</p>

To give good performance with a variety of sensor types, many frequency-to-analog converters, including the GPI Remote Transmitter, offer two or more settings for “response time” (sometimes referred to as “setting time, or “averaging time”).

- Longer (slower) response times are needed for sensor types that generate very low frequency outputs (like oval gear flowmeters).
- Shorter (faster) response times are preferable for sensors that generate higher frequency outputs (GPI meters, for example).
- Longer (slower) response times are also appropriate in situations where sensor-output frequency fluctuates or wobbles substantially.

The GPI Remote Transmitter offers a choice of five response-time settings, selectable by the unit’s pushbuttons.

Procedure

1. Start with the transmitter unpowered. If the transmitter is presently operating, temporarily disable its external power supply. Be sure to allow at least 30 seconds to elapse with unit unpowered.
2. Press and hold the “4” button. While holding, watch the indicator light and power up the transmitter.
3. Shortly after power is applied, the light will blink one or more times. Count the number of blinks (from 1 to 5 blinks) and release the button after the blinking has finished.

NOTE: If necessary, repeat steps 1 through 3 to get the number of blinks corresponding to the response time you want.

Blinks	Response Time
1 blink	0.3 second
2 blinks	0.7 second
3 blinks	1.3 second
4 blinks	2.6 second
5 blinks	5.2 second

In normal operation, the transmitter always averages two sequential input readings. The time delay from an abrupt change in input frequency to a final, stabilized output reading is always twice that shown in the above table.

MAINTENANCE

Check cable-entry seals periodically. Tighten and/or apply sealant if needed. This is especially important in environments containing heavy concentrations of dust, oil mist, or other residue.

Check all wiring connections occasionally for oxidation or corrosion. Clean and re-seat if such conditions are noted.

If necessary, check and re-seat any connections that may have been subjected to strain (during rework or construction, for example).

TROUBLESHOOTING

SYMPTOM	PROBABLE CAUSE	CORRECTIVE ACTION
A. METER IS NOT ACCURATE	<ol style="list-style-type: none"> 1. Field Calibration not performed properly. 2. Factory Calibration not suitable for liquid being measured. 3. Improper installation of flow-meter. 4. Flow rates too high or too low. 	<p>Field Calibrate again or select Factory Calibration.</p> <p>Perform a Field Calibration according to Calibration Section.</p> <p>Check for electrical noise, pulsation or swirl in the flow.</p> <p>See section on display calibration for flow rates.</p>
B. READOUT FADED OR BLANK	<ol style="list-style-type: none"> 1. Power not connected. 2. Computer defective. 3. Temperature limits exceeded. 	<p>Check power supply.</p> <p>Contact the factory.</p> <p>Check temperature specifications.</p>
C. NORMAL FLOW RATE BUT METER DOES NOT COUNT (Meter comes on when DISPLAY button pushed)	<ol style="list-style-type: none"> 1. Field Calibration not performed correctly. 2. Computer defective. 3. Loose wire or mis-wired. 4. Sensor not attached to turbine. 5. Faulty sensor. 	<p>Field Calibrate again or select Factory Calibration.</p> <p>Contact the factory.</p> <p>Check wiring diagram.</p> <p>Check continuity of sensor.</p> <p>Contact the factory.</p>
D. CANNOT GET METER INTO FIELD CALIBRATION	<ol style="list-style-type: none"> 1. Factory Calibration (PRESET) curve active. 2. Computer circuit board defective. 3. Wrong button sequence. 4. Not holding button long enough or hard enough. 5. Button defective. 	<p>Hold down CALIBRATE and push and release DISPLAY until PRESET flag goes off. Proceed with calibration according to the Calibration Section.</p> <p>Replace computer. Contact the factory.</p> <p>Recalibrate.</p> <p>Hold button until the appropriate response appears in the display.</p> <p>Replace computer. Contact the factory.</p>
E. COMPUTER BLINKS "NO" AFTER FIELD CALIBRATION	<ol style="list-style-type: none"> 1. Flow rate too low. 2. Flow rate too high. 3. Rotor not spinning freely. 4. Volume too low. 5. Loose wiring. 6. Faulty sensor. 	<p>Try again and increase flow rate to minimum calibration rate. See Calibration Section.</p> <p>Maximum flow rate is usually 10:1 turndown or 10x minimum flow rate.</p> <p>Remove meter. Clean carefully. Make sure rotor spins freely.</p> <p>See section on display calibration for minimum flow rate.</p> <p>Check wiring.</p> <p>Contact the factory.</p>

TROUBLESHOOTING

SYMPTOM	PROBABLE CAUSE	CORRECTIVE ACTION
F. LOOP OUTPUT "STUCK" AT ZERO (No reading at all, regardless of input signal.)	<ol style="list-style-type: none"> 1. Loop not supplying power. 2. Loop connections bad. 3. Transmitter is faulty. 	<p>Be sure loop power supply is present and working, and has correct polarity.</p> <p>Check all loop connections for open- or short-circuits.</p> <p>Replace transmitter.</p>
G. LOOP OUTPUT "STUCK" AT LOW VALUE (Between 1 and 4 mA) REGARDLESS OF INPUT SIGNAL	<ol style="list-style-type: none"> 1. 4mA / 20mA setpoints bad or not set. 2. No input signal. 3. Input connections bad. 4. Transmitter is faulty. 	<p>Perform new setpoint procedure for both 4mA and 20mA points.</p> <p>Verify presence of input signal at terminal block.</p> <p>Check all signal-input connections for open- or short-circuits.</p> <p>Replace transmitter.</p>
H. LOOP OUTPUT "STUCK" AT FULL-SCALE (above 20mA) REGARDLESS OF INPUT SIGNAL	<ol style="list-style-type: none"> 1. 4mA / 20mA setpoints bad or not set. 2. Short-circuit between Loop (-) and LOCAL-COM circuits. 	<p>Perform new setpoint procedure for both 4mA and 20mA points.</p> <p>Check all Loop and LOCAL-COM circuitry for shorts.</p>
I. LOOP OUTPUT WITHIN NORMAL RANGE, BUT INCORRECT	<ol style="list-style-type: none"> 1. 4mA / 20mA setpoints bad or not set. 	<p>Perform new setpoint procedure for both 4mA and 20mA</p>
J. LOOP OUTPUT "BOUNCES" ERRATICALLY (is unstable)	<ol style="list-style-type: none"> 1. Output response-time setting too short, especially for slow input signal. 2. Input connections bad. 	<p>Select a longer response-time setting.</p> <p>Check all signal-input connections for intermittent open- or short-circuits.</p>
K. LOOP-OUTPUT STABLE BUT RESPONSE TIME TOO SLOW	<ol style="list-style-type: none"> 1. Output response-time setting too long, especially for fast input signal. 	<p>Select a shorter response-time setting.</p>
L. LOOP-OUTPUT OK, BUT 0-5 V OUTPUT DOESN'T WORK	<ol style="list-style-type: none"> 1. 0-5 V output loaded too heavily. 	<p>Be sure 0-5 V load impedance is at least 1000 ohms (1KΩ).</p>
M. LOOP AND 0-5V OUTPUTS OK, BUT OPEN-COLLECTOR PULSE-OUT OUTPUT DOESN'T WORK	<ol style="list-style-type: none"> 1. No pull-up resistor or pull-up power. 	<p>Be sure pull-up resistor and pull-up power present, with</p>

DIMENSIONS

PIPE MOUNT DIMENSIONS

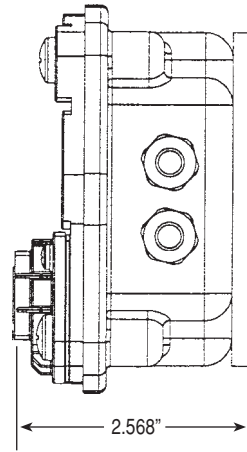
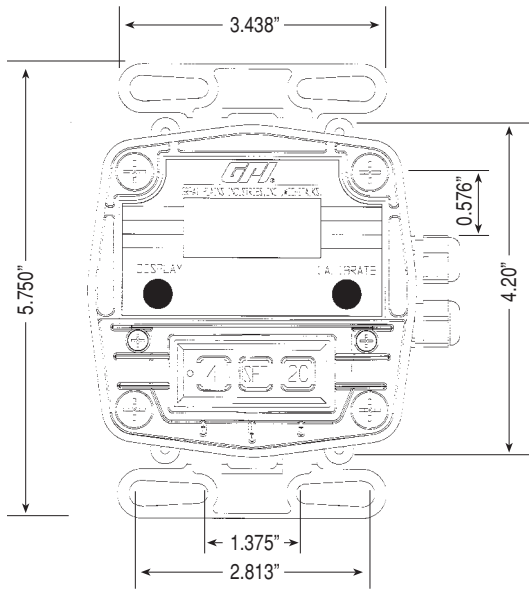

WALL MOUNT DIMENSIONS

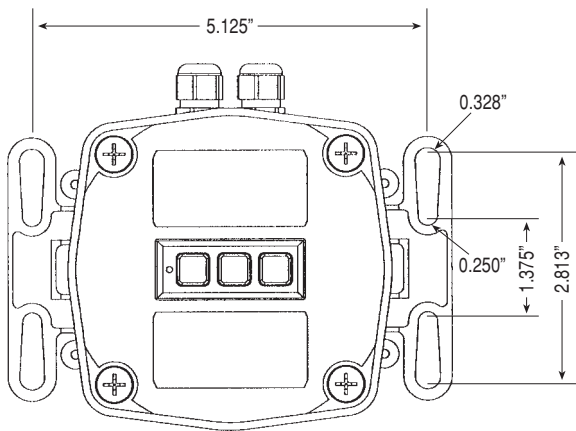

PANEL CUT-OUT DIMENSIONS

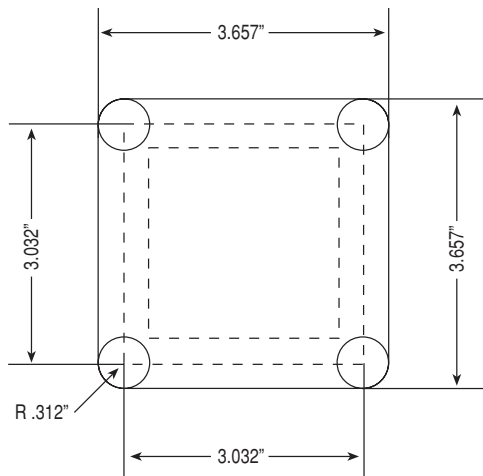

SPECIFICATIONS

Mechanical:

Enclosure:	Equiv. to NEMA 4/IP65
Strain Relief:	Hubble PG7 Grip range 0.11-0.26
Strain Relief Thread:	Female 1/2-20 UNF-2B
Cable:	Belden 9363 (22AWG-2 conductor w/drain wire and shield)
Cable Length:	20 ft (6m) provided
Operation Temperature:	+14°F to 140°F (-10°C to 60°C)
Storage Temperature (with display):	-40°F to 158°F (-40°C to 70°C)

Power Supply:

Type:	2-wire system - Loop powered w/reverse polarity protection
Voltage Requirement:	
Minimum:	8.5 VDC
Maximum:	35 VDC (higher voltage may damage unit)

Primary Output (4-20mA or 0-20mA):

Type:	Loop
-------	------

Auxiliary Outputs:

0-5 V

Type:	Single-ended
-------	--------------

Pulse-Out

Type:	Open collector NPN (current sinking)
Max. "OFF" voltage:	60 V
Max. "ON" current:	200 mA
Max. "ON" voltage drop:	< 0.5V @ 200mA

EDM-Pwr

Type:	Can supply regulated 5 VDC at up to 2.5mA to external circuitry
-------	---

Sensor Options

(For use with GPI A2 Turbine Meters)

Turbine Mounted Display Option:

Output Type:	Open Collector
Display Type:	Both Local and Remote Display
Sensor to Transmitter Distance:	25 ft. (Can reach up to 250 ft. with addition of customer-supplied pull-up resistor and 5,000 ft. with addition of customer-supplied pull-up resistor and external power source)

Conditioned Signal Sensor Option:

Output Type:	Open Collector
Display Type:	Remote Display Only
Sensor to Transmitter Distance:	25 ft. (Can reach up to 250 ft. with addition of customer-supplied pull-up resistor and 5,000 ft. with addition of customer-supplied pull-up resistor and external power source)

Standard Remote Sensor Option:

Output Type:	Low Level Sine Wave
Display Type:	Remote Display with Low or High Temperature liquids -40°F to 250°F (-40°C to 121°C)
Sensor to Transmitter Distance:	Up to 20 ft.

Frequency Inputs (Remote Display):

Low Level Coil (LLC):	Frequency Range 0-1000 Hz (waveform dependent)
High-Level Low Frequency (HLLF):	Frequency Range 0-150 Hz (debounced, waveform dependent)
High Level High Frequency (HLHF):	Frequency Range 0-1200 Hz (not debounced, requires clean logic level square or rectangular waveform)
Optically isolated HLLF:	Same as HLLF with 2500 V optical isolation
Optically isolated HLHF:	Same as HLHF with 2500 V optical isolation

NOTE: GPI A2 Turbine Meter Sensors use High Level High Frequency (HLHF) input. For other sensor types, call GPI Customer Support for technical specifications.

Performance:

Max. Conversion Error:	(nonlinearity plus span, any input, loop-current output, 0°C to 70°C, loop voltage supply 12 VDC to 24 VDC) 0.5% of span plus possible resolution uncertainty.
Max. Conversion-Resolution Uncertainty:	(Loop-current output, when properly calibrated) Larger of 0.1 mA or $[20 \text{ mA} / (10 \times (f_{20} - f_4))]$. Where f_{20} = frequency at 20 mA, f_4 = frequency at 4 mA.
Speed of Response:	After step change in input frequency, loop output guaranteed stable within 3 x accumulating-time (Accumulating-time user selectable from 0.3 sec, 0.7 sec, 1.3 sec, 2.6 sec, 5.2 sec).

PARTS LIST

Part No.	Description
120048-01	Gasket
120058-01	Bracket
120509-01	Adapter Kit
120510-01	Circuit Kit (Main)
120511-01	Computer Kit
120512-01	Switch Keypad Kit (Small Cover)
120513-01	Strain Relief Kit
125066-3	Cable, 100 feet
125066-20	Cable, 20 feet
901002-82	O-Ring
904005-27	Sems Screw and Washer (2 ea. required)
904005-28	Sealing Screw (4 ea. required)

SERVICE

For warranty consideration, parts, or other service information, please contact your local distributor. If you need further assistance, contact the GPI Customer Service Department in Wichita, Kansas, during normal business hours.

Tel: 316-686-7361
Fax: 316-686-6746

To obtain prompt, efficient service, always be prepared with the following information:

- The model number
- The manufacturing date code

The date code is a four-digit number (XXXX) located under the coverplate.

For warranty work, always be prepared with your original sales slip or other evidence of purchase date.

Please contact GPI before returning any part. It may be possible to diagnose the trouble and find a solution with a telephone call. GPI can also inform you of any special requirements you will need to follow for shipping.

SAVE THESE INSTRUCTIONS

Limited Warranty Policy

Great Plains Industries, Inc. 5252 E. 36th Street North, Wichita, KS USA 67220-3205, hereby provides a limited **one year warranty** against defects in material and workmanship on all products manufactured by Great Plains Industries, Inc. except models BP-10, BP-12, LP-50, RP-5 and CP-5. These models carry a 90-day warranty. The warranty shall extend to the purchaser of this product and to any person to whom such product is transferred during the warranty period.

The warranty period shall begin on the date of the original new equipment purchase. Warrantor's obligation hereunder shall be limited to repairing defective workmanship or replacing or repairing any defective part or parts. This warranty shall not apply if:

- A. the product has been altered or modified outside the warrantor's duly appointed representative;
- B. the product has been subjected to neglect, misuse, abuse or damage or has been installed or operated other than in accordance with the manufacturer's operating instructions.

To make a claim against this warranty, notice of claim must be given in writing to the company at its above address no later than 30 days after the expiration of the warranty period. Such notice shall identify the defect in the product. The company shall, within 14 days of receipt of such notice, notify the customer to either send the product, transportation prepaid, to the company at its office in Wichita, Kansas, or to duly authorized service center. The company shall perform all obligations imposed on it by the terms of this warranty within 60 days of receipt of the defective product.

GREAT PLAINS INDUSTRIES, INC. EXCLUDES LIABILITY UNDER THIS WARRANTY FOR DIRECT, INDIRECT, INCIDENTAL AND CONSEQUENTIAL DAMAGES INCURRED IN THE USE OR LOSS OF USE OF THE PRODUCT WARRANTED HEREUNDER.

The company herewith expressly disclaims any warranty of merchantability or fitness for any particular purpose other than for which it was designed.

This warranty gives you specific rights and you may also have other rights which vary from U.S. state to U.S. state.

Note: In compliance with MAGNUSON MOSS CONSUMER WARRANTY ACT – Part 702 (governs the resale availability of the warranty terms).



5252 East 36th Street North
Wichita, KS USA 67220-3205
TEL: 316-686-7361
FAX: 316-686-6746

GREAT PLAINS INDUSTRIES, INC.

"A Great Plains Ventures Subsidiary"

www.gpi.net

1-888-996-3837