

SAVE THESE INSTRUCTIONS



5252 East 36th Street North
Wichita, KS USA 67220-3205
TEL: 316-686-7361
FAX: 316-686-6746

GREAT PLAINS INDUSTRIES, INC.

"A Great Plains Ventures Subsidiary"

www.gpi.net

1-888-996-3837

Industrial Grade Remote Pulse Out Transmitter

Owner's Manual

Manual No. 920765-04

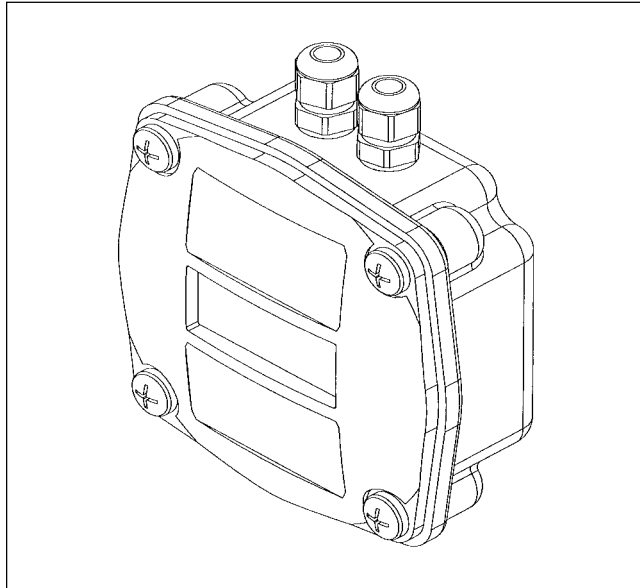

To the owner...

Congratulations on receiving your GPI Remote Transmitter. We are pleased to provide you with a product designed to give you maximum reliability and efficiency.

Our business is the design, manufacture, and marketing of liquid handling, agricultural, and recreational products. We succeed because we provide customers with innovative, reliable, safe, timely, and competitively-priced products. We pride ourselves in conducting our business with integrity and professionalism.

We are proud to provide you with a quality product and the support you need to obtain years of safe, dependable service.

President
Great Plains Industries, Inc.

TABLE OF CONTENTS

General Information	1
Product Description	1
Safety Instructions	2
Installation	2
Wiring	2
Troubleshooting	4
Maintenance	4
Dimensions	4
Specifications	5
Parts List	6
Service	6

The Remote Transmitter can be configured to provide pulse output using low level sine wave (Standard Remote option) or square wave (Conditioned Signal option) inputs. Details on using the transmitter with other meters can be obtained from GPI customer service.

PRODUCT DESCRIPTION

The GPI Remote Transmitter is a signal conditioner with industry standard pulse output. The Remote Transmitter accepts input pulses from a turbine meter or other frequency generating meter, and can transmit those pulses to customer equipment up to 5,000 feet away. The transmitter is powered by customer-supplied external power. The transmitter can be pipe, wall, or panel mounted.

GENERAL INFORMATION

This manual will assist you in operating and maintaining the computer electronics of the GPI Remote Transmitter. Included in this manual is information on wiring the pulse output to your equipment.

This manual is for use with GPI A2 Series Turbine Meters only (Models 050, 075, 100, 150, 200, and 250 in stainless steel, PVC, PVDF, brass, and aluminum).

CAUTION

This transmitter is not yet FM Approved. Therefore, use of this transmitter with an approved metering system voids FM Approval.

NOTE: This transmitter is externally powered, requiring an input power supply of 8.5 to 35 volts (24 VDC is recommended).

SAFETY INSTRUCTIONS

- When measuring flammable liquids, observe precautions against fire or explosion.
- When working in hazardous environments, always exercise appropriate safety precautions.
- When applying external power to the transmitter, use DC power only.
- Disconnect external power to the transmitter before detaching or attaching input or output wires.
- Ground loops between sensor and user equipment can damage the transmitter and can be dangerous.
- If you cannot galvanically isolate the sensor from earth ground, you may need to use the transmitter's optically isolated inputs.
- Be sure O-rings and seals are kept in good repair.

INSTALLATION

⚠ CAUTION

Installation should be performed only by qualified personnel, and in accordance with local governing regulations.

Environmental

Choose a mounting location suitable for the remote transmitter. The ideal mounting location is where the:

- turbine meter is as close as possible.
- mounting surface has minimal vibration.
- ambient temperature is +30°F to 140°F (0°C to 60°C) when using remote display.
- cable lengths are minimal.

Avoid mounting locations where the remote transmitter is:

- subject to constant exposure to water or other liquids (occasional low-pressure splashing will not harm unit if cable entry points are well-sealed).
- subject to > 5g shock loading.
- facing the sun directly for long periods of time.
- close to high voltage/current runs, DC motors, internal combustion engines, or frequency inverters.

Sensor Cabling

- GPI A2 Turbine Sensors are sold as part of the Remote Transmitter and come with 20 ft. of shielded cable.
- If you require a longer cable, a 100 ft. cable kit is available from GPI, or use Belden 9363 cable. When wiring longer lengths of cable, be sure to connect the shield to transmitter LOCAL-COM ONLY! (Multiple shield connections may cause ground-loop problems).
- Some trial and error may be needed because of the wide variety of user conditions. Try to keep cable lengths short!

WIRING

If you ordered your Remote Transmitter to use with a GPI A2 Industrial Meter, the transmitter comes with 20 ft. of cable to connect to the meter. The customer must supply the power supply. Connect the power source to the LOOP (+) and LOOP (-) terminals, as shown in the following diagrams.

Connecting the Equipment:

- Remove the faceplate by removing the four (4) corner screws.
- Attach wiring from your equipment according to the following terminal connections and wiring diagrams, depending on your circumstances.

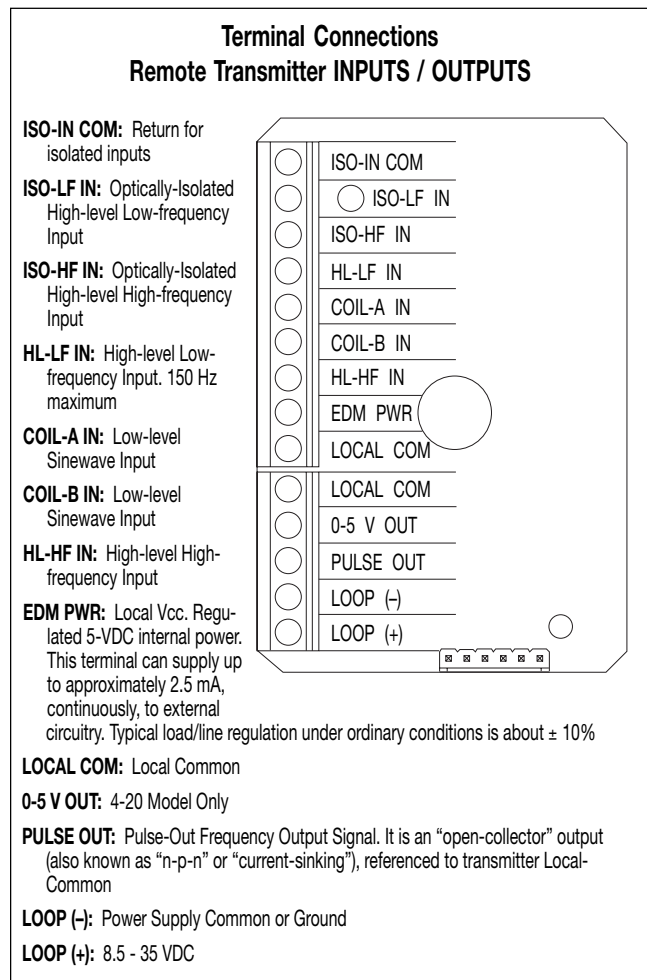

WIRING DIAGRAM 1

— GPI A2-Series Turbine with Local Display & Conditioned Signal Option —
Customer Equipment with Frequency Sensing and Separate Loop Power Supply

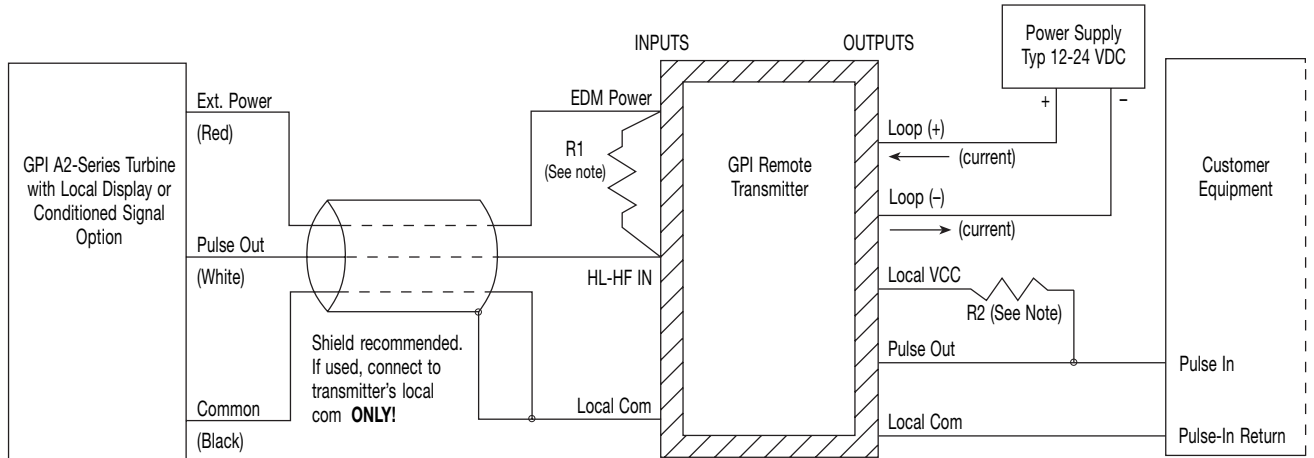

Note Regarding Input Pull-Up Resistor "R1":
 R1 not generally required for distance up to 25 ft.
 Use R1 = 10k (10000 ohms) for distance up to 50 ft.
 Use R1 = 5.1k (5100 ohms) for distance up to 100 ft.
 Use R1 = 2.7k (2700 ohms) for distance up to 250 ft.
 Do not use R1 less than 2.4k (ohms)

Additional Notes:
 Loop power supply electrically isolated from customer equipment.
 Actual value of loop current (mA) is disregarded.
 Output pull-up resistor R2 only required if customer equipment has no internal pull-up resistor on pulse-in input. Typical value 5,000 to 10,000 ohms.

WIRING DIAGRAM 2

— GPI A2-Series Turbine with Remote-Sensor Option —
Customer Equipment with Frequency Sensing and Separate Loop Power Supply

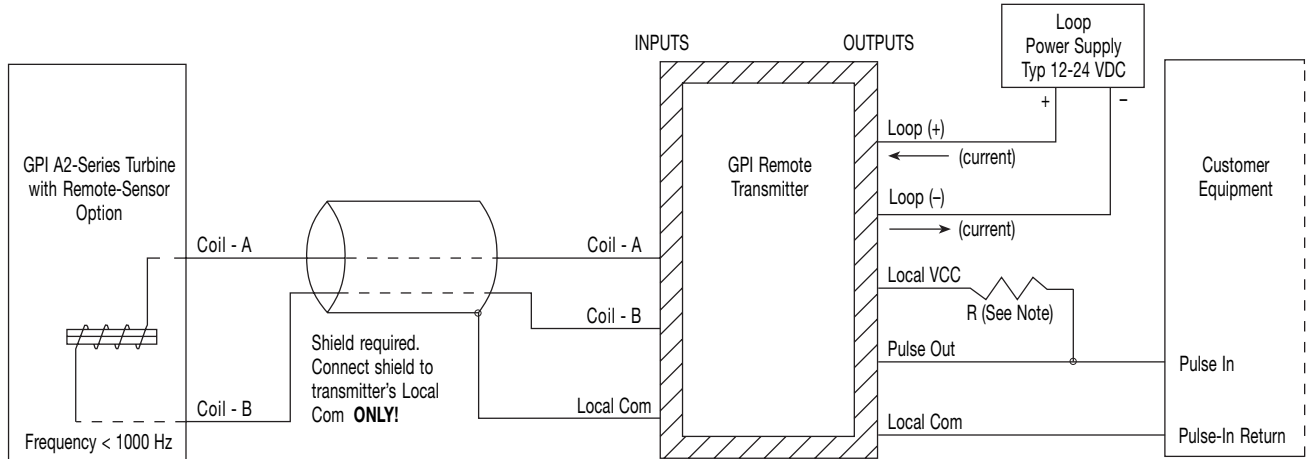

Notes: Minimum signal amplitude required for normal operation approx. 15 mV P-P.
 Recommended cable type - twisted pair with shield.
 Recommended maximum cable length - 20 ft.
 Loop power supply electrically isolated from customer equipment.
 Actual value of loop current (mA) is disregarded.
 Output pull-up resistor R only required if customer equipment has no internal pull-up resistor on pulse-in input. Typical value 5,000 to 10,000 ohms..

TROUBLESHOOTING

A. Pulse-out output doesn't work.

1. **No pull-up resistor or pull-up power.** Be sure pull-up resistor and pull-up power present, with correct polarity.

MAINTENANCE

Check cable-entry seals periodically. Tighten and/or apply sealant if needed. This is especially important in environments containing heavy concentrations of dust, oil mist, or other residue.

Check all wiring connections occasionally for oxidation or corrosion. Clean and re-seat if such conditions are noted.

If necessary, check and re-seat any connections that may have been subjected to strain (during rework or construction, for example).

DIMENSIONS

PIPE MOUNT DIMENSIONS

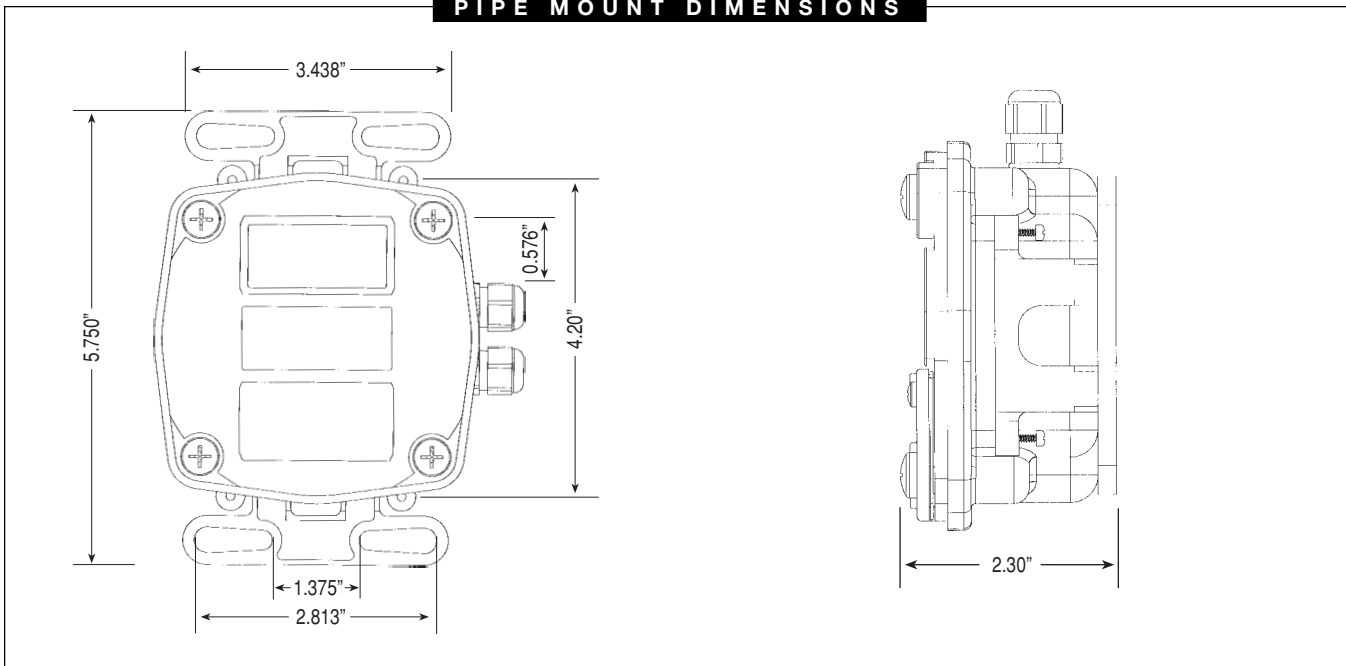

WALL MOUNT DIMENSIONS

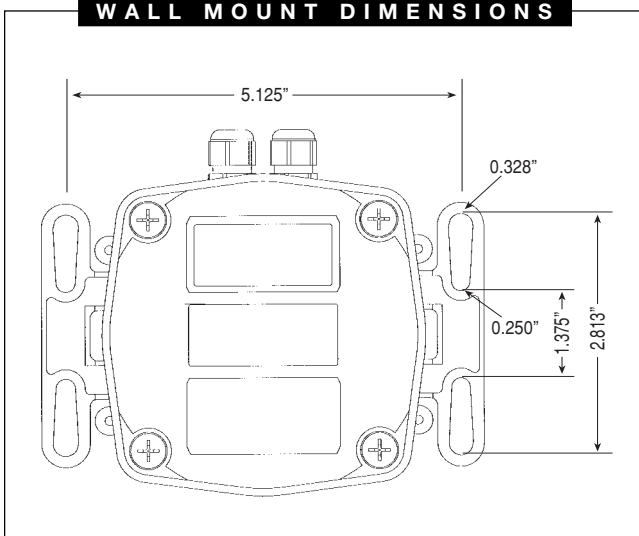

PANEL CUT-OUT DIMENSIONS

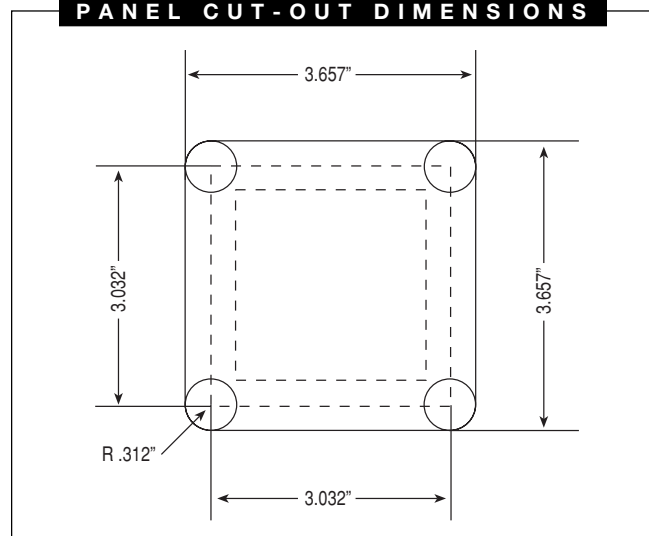

SPECIFICATIONS

Mechanical:

Enclosure:	Equiv. to NEMA 4/IP65
Strain Relief:	Hubble PG7 Grip range 0.11-0.26
Strain Relief Thread:	Female 1/2-20 UNF-2B
Cable:	Belden 9363 (22AWG-2 conductor w/drain wire and shield)
Cable Length:	20 ft (6m) provided
Operation Temperature:	+14°F to 140°F (-10°C to 60°C)
Storage Temperature (with display):	-40°F to 158°F (-40°C to 70°C)

Power Supply:

Voltage Requirement:	
Minimum:	8.5 VDC
Maximum:	35 VDC (higher voltage may damage unit)

Primary Output:

Pulse-Out

Type:	Open collector NPN (current sinking)
Max. "OFF" voltage:	60 V
Max. "ON" current:	200 mA
Max. "ON" voltage drop:	< 0.5V @ 200mA

Auxiliary Outputs:

EDM-Pwr

Type:	Can supply regulated 5 VDC at up to 1.5mA to external circuitry
-------	---

Sensor Options

(For use with GPI A2 Turbine Meters)

Turbine Mounted Display Option:

Output Type:	Open Collector
Display Type:	Both Local and Remote Display
Sensor to Transmitter Distance:	Up to 25 ft. as supplied. Can reach up to 250 ft. with addition of customer-supplied pull-up resistor.

Conditioned Signal Sensor Option:

Output Type:	Open Collector
Display Type:	Remote Display Only
Sensor to Transmitter Distance:	Up to 25 ft. as supplied. Can reach up to 250 ft. with addition of customer-supplied pull-up resistor.

Standard Remote Sensor Option:

Output Type:	Low Level Sine Wave
Display Type:	Remote Display with Low or High Temperature liquids -40°F to 250°F (-40°C to 121°C)
Sensor to Transmitter Distance:	Up to 20 ft.

Frequency Inputs (Remote Transmitter):

Low Level Coil (LLC):	Frequency Range 0-1000 Hz (waveform dependent)
High-Level Low Frequency (HLLF):	Frequency Range 0-150 Hz (debounced, waveform dependent)
High Level High Frequency (HLHF):	Frequency Range 0-1200 Hz (not debounced, requires clean logic level square or rectangular waveform)
Optically isolated HLLF:	Same as HLLF with 2500 V optical isolation
Optically isolated HLHF:	Same as HLHF with 2500 V optical isolation

NOTE: GPI A2 Turbine Meter Sensors use High Level High Frequency (HLHF) input. For other sensor types, call GPI Customer Support for technical specifications.

PARTS LIST

Part No.	Description
120048-01	Gasket
120058-01	Bracket
120509-01	Adapter Kit
120510-01	Circuit Kit (Main)
120511-01	Computer Kit
120512-01	Optional Add-on 4-20 Board
120513-01	Strain Relief Kit
125066-3	Cable, 100 feet
125066-20	Cable, 20 feet
901002-82	O-Ring
904005-27	Sems Screw and Washer (2 ea. required)
904005-28	Sealing Screw (4 ea. required)

SERVICE

For warranty consideration, parts, or other service information, please contact your local distributor. If you need further assistance, contact the GPI Customer Service Department in Wichita, Kansas, during normal business hours.

Tel: 316-686-7361
Fax: 316-686-6746

To obtain prompt, efficient service, always be prepared with the following information:

- The model number
- The manufacturing date code

The date code is a four-digit number (XXXX) located under the coverplate.

For warranty work, always be prepared with your original sales slip or other evidence of purchase date.

Please contact GPI before returning any part. It may be possible to diagnose the trouble and find a solution with a telephone call. GPI can also inform you of any special requirements you will need to follow for shipping.

SAVE THESE INSTRUCTIONS

Limited Warranty Policy

Great Plains Industries, Inc. 5252 E. 36th Street North, Wichita, KS USA 67220-3205, hereby provides a limited **one year warranty** against defects in material and workmanship on all products manufactured by Great Plains Industries, Inc. except models BP-10, BP-12, LP-50, RP-5 and CP-5. These models carry a 90-day warranty. The warranty shall extend to the purchaser of this product and to any person to whom such product is transferred during the warranty period.

The warranty period shall begin on the date of the original new equipment purchase. Warrantor's obligation hereunder shall be limited to repairing defective workmanship or replacing or repairing any defective part or parts. This warranty shall not apply if:

- A. the product has been altered or modified outside the warrantor's duly appointed representative;
- B. the product has been subjected to neglect, misuse, abuse or damage or has been installed or operated other than in accordance with the manufacturer's operating instructions.

To make a claim against this warranty, notice of claim must be given in writing to the company at its above address no later than 30 days after the expiration of the warranty period. Such notice shall identify the defect in the product. The company shall, within 14 days of receipt of such notice, notify the customer to either send the product, transportation prepaid, to the company at its office in Wichita, Kansas, or to duly authorized service center. The company shall perform all obligations imposed on it by the terms of this warranty within 60 days of receipt of the defective product.

GREAT PLAINS INDUSTRIES, INC. EXCLUDES LIABILITY UNDER THIS WARRANTY FOR DIRECT, INDIRECT, INCIDENTAL AND CONSEQUENTIAL DAMAGES INCURRED IN THE USE OR LOSS OF USE OF THE PRODUCT WARRANTED HEREUNDER.

The company herewith expressly disclaims any warranty of merchantability or fitness for any particular purpose other than for which it was designed.

This warranty gives you specific rights and you may also have other rights which vary from U.S. state to U.S. state.

Note: In compliance with MAGNUSON MOSS CONSUMER WARRANTY ACT – Part 702 (governs the resale availability of the warranty terms).



5252 East 36th Street North
Wichita, KS USA 67220-3205
TEL: 316-686-7361
FAX: 316-686-6746

GREAT PLAINS INDUSTRIES, INC.

"A Great Plains Ventures Subsidiary"

www.gpi.net

1-888-996-3837