

**SAVE THESE INSTRUCTIONS**



5252 East 36th Street North  
Wichita, KS USA 67220-3205  
TEL: 316-686-7361  
FAX: 316-686-6746

**GREAT PLAINS INDUSTRIES, INC.**

"A Great Plains Ventures Subsidiary"

www.gpi.net

1-888-996-3837

# Industrial Grade Remote 4-20mA Transmitter

## Owner's Manual

Manual No. 920765-03

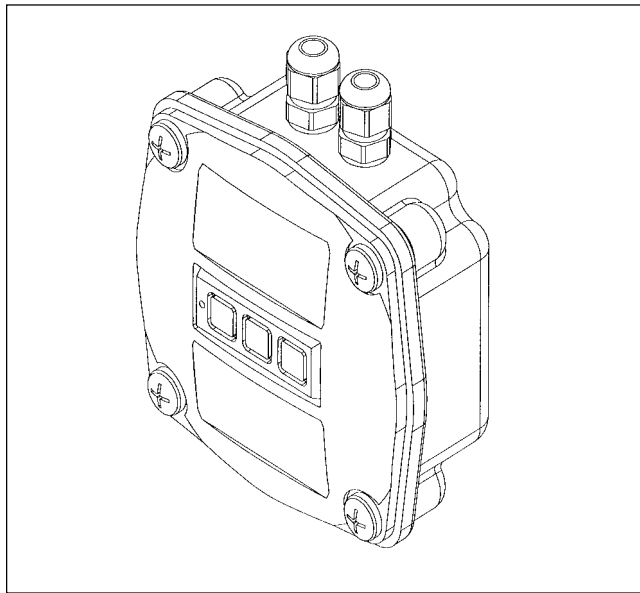

### To the owner...

Congratulations on receiving your GPI Remote Transmitter. We are pleased to provide you with a product designed to give you maximum reliability and efficiency.

Our business is the design, manufacture, and marketing of liquid handling, agricultural, and recreational products. We succeed because we provide customers with innovative, reliable, safe, timely, and competitively-priced products. We pride ourselves in conducting our business with integrity and professionalism.

We are proud to provide you with a quality product and the support you need to obtain years of safe, dependable service.

President  
Great Plains Industries, Inc.

## TABLE OF CONTENTS

General Information .....	1
Product Description .....	2
Safety Instructions .....	2
Installation .....	2
Wiring .....	3
Operations .....	6
Maintenance .....	7
Troubleshooting .....	8
Dimensions .....	9
Specifications .....	10
Parts List .....	11
Service .....	11

## GENERAL INFORMATION

This manual will assist you in operating and maintaining the computer electronics of the GPI Remote Transmitter. Included in this manual is information on calibrating the 4-20mA output.

This manual is for use with GPI A2 Series Turbine Meters only (Models 050, 075, 100, 150, 200, and 250 in stainless steel, PVC, PVDF, brass, and aluminum).

The Remote Transmitter can be configured to transmit 4-20mA output proportional to the flowrate. Details on using the transmitter with other meters can be obtained from GPI customer service.

## PRODUCT DESCRIPTION

The GPI Remote Transmitter is a flow totalizer and rate meter with industry standard current loop output. The Remote Transmitter accepts input pulses from a turbine meter or other frequency generating meter, and uses those pulses to calculate the flow total and rate in a pipeline. The unit is loop powered, and provides a 4-20mA analog output proportional to the frequency signal for communication with PLCs and other customer equipment. The 4-20mA (or 0-20mA) output is calibrated under actual flow conditions with simple push-button calibration. Auxiliary output includes 0-5 VDC and pulse output. The transmitter can be pipe, wall, or panel mounted.

The microprocessor-based electronics have extremely low power requirements and are completely powered by the 4-20 loop. All operations are easily accessed with the push buttons on the display front panel.

### **⚠ CAUTION**

**This transmitter is not yet FM Approved. Therefore, use of this transmitter with an approved metering system voids FM Approval.**

**NOTE:** This transmitter is loop powered, requiring an input power supply of 8.5 to 35 volts (24 VDC is recommended).

**NOTE:** Setpoint calibration of the transmitter is required for the 4-20mA, 0-20mA, and 0-5 V output options.

## SAFETY INSTRUCTIONS

- When measuring flammable liquids, observe precautions against fire or explosion.
- When working in hazardous environments, always exercise appropriate safety precautions.
- When applying external power to the transmitter, use DC power only.
- Disconnect external power to the transmitter before detaching or attaching input or output wires.
- Ground loops between sensor and user equipment can damage the transmitter and can be dangerous.
- If you cannot galvanically isolate the sensor from earth ground, you may need to use the transmitter's optically isolated inputs.
- Be sure O-rings and seals are kept in good repair.

## INSTALLATION

### **⚠ CAUTION**

**Installation should be performed only by qualified personnel, and in accordance with local governing regulations.**

### Environmental

Choose a mounting location suitable for the remote transmitter. The ideal mounting location is where the:

- turbine meter is as close as possible.
- mounting surface has minimal vibration.
- ambient temperature is +30°F to 140°F (0°C to 60°C) when using remote display.
- cable lengths are minimal.

Avoid mounting locations where the remote transmitter is:

- subject to constant exposure to water or other liquids (occasional low-pressure splashing will not harm unit if cable entry points are well-sealed).
- subject to > 5g shock loading.
- facing the sun directly for long periods of time.
- close to high voltage/current runs, DC motors, internal combustion engines, or frequency inverters.

### Cable Guidelines

4-20mA Current Loop:

- The current loop itself is very resistant to electrical noise pickup and shielded cable is seldom needed except in very "noisy" (electrical) locations and/or when very long runs (thousands of feet) are used.

Sensor Cabling:

- GPI A2 Turbine Sensors are sold as part of the Remote Transmitter and come with 20 ft. of shielded cable.
- If you require a longer cable, a 100 ft. cable kit is available from GPI, or use Belden 9363 cable. When wiring longer lengths of cable, be sure to connect the shield to transmitter LOCAL-COM ONLY! (Multiple shield connections may cause ground-loop problems).
- Some trial and error may be needed because of the wide variety of user conditions. Try to keep cable lengths short!

## WIRING

If you ordered your Remote Transmitter to use with a GPI A2 Industrial Meter, the transmitter comes with 20 ft. of cable to connect to the meter. The customer must supply the communication loop cable. Although the transmitter is usually powered through the communication loop, there are some circumstances that might require external power.

### Connecting the Equipment:

- Remove the faceplate by removing the four (4) corner screws.
- Attach wiring from your equipment according to the following terminal connections and wiring diagrams, depending on your circumstances.

### Terminal Connections Remote Transmitter INPUTS / OUTPUTS

<p><b>ISO-IN COM:</b> Return for isolated inputs</p> <p><b>ISO-LF IN:</b> Optically-Isolated High-level Low-frequency Input</p> <p><b>ISO-HF IN:</b> Optically-Isolated High-level High-frequency Input</p> <p><b>HL-LF IN:</b> High-level Low-frequency Input. 150 Hz maximum</p> <p><b>COIL-A IN:</b> Low-level Sinewave Input</p> <p><b>COIL-B IN:</b> Low-level Sinewave Input</p> <p><b>HL-HF IN:</b> High-level High-frequency Input</p> <p><b>EDM PWR:</b> Local Vcc. Regulated 5-VDC internal power. This terminal can supply up to approximately 2.5 mA, continuously, to external circuitry. Typical load/line regulation under ordinary conditions is about <math>\pm 10\%</math></p> <p><b>LOCAL COM:</b> Local Common</p> <p><b>0-5 V OUT:</b> 0 to 5 V Voltage Output. Frequency to Analog Output.</p> <p><b>PULSE OUT:</b> Pulse-Out Frequency Output Signal. It is an "open-collector" output (also known as "n-p-n" or "current-sinking"), referenced to transmitter Local-Common</p> <p><b>LOOP (-):</b> 4 to 20 mA Current Loop – current into transmitter</p> <p><b>LOOP (+):</b> 4 to 20 mA Current Loop – current out of transmitter</p>	
--	--

## WIRING DIAGRAM 1

### — 4-20mA or 0-20mA Output —

#### Customer Equipment with Built-in Power Supply

Input: Turbine Mounted Display or Conditioned Signal Sensor (Open Collector)  
Output: Customer Equipment, 0-20mA Sensing, Built-in Loop Power Supply

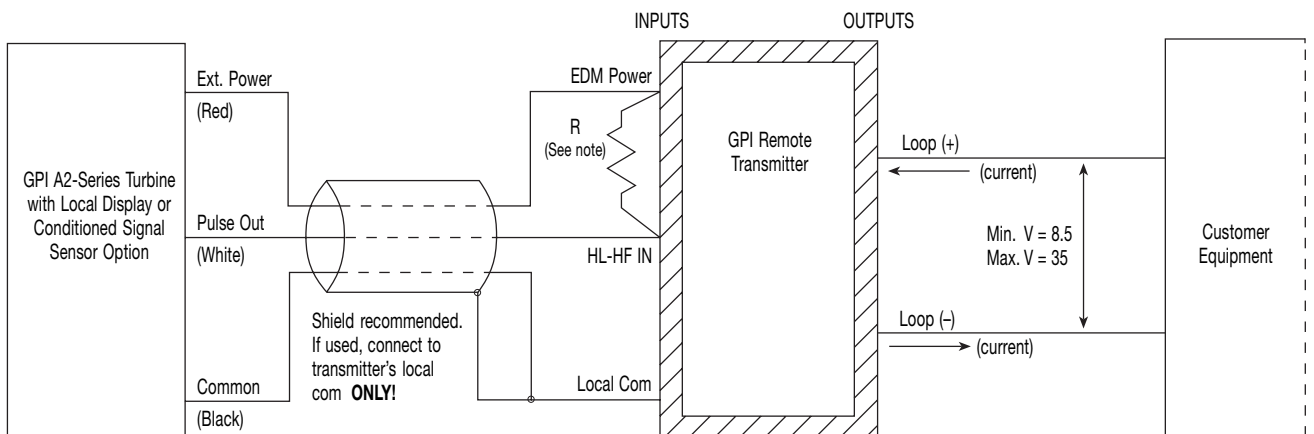

Note Regarding Resistor "R": R not generally required for distance up to 25 ft.  
Use R = 10k (10000 ohms) for distance up to 50 ft.  
Use R = 5.1k (5100 ohms) for distance up to 100 ft.  
Use R = 2.7k (2700 ohms) for distance up to 250 ft.  
Do not use R less than 2.4k (ohms)

**CAUTION:** When reassembling the faceplate, make sure that the enclosure seal is not crimped or twisted. Do not over-tighten corner screws (hand tighten only). Faceplate can be rotated 90°.

**WIRING DIAGRAM 2**

**— 4-20mA or 0-20mA Output —**

**Customer Equipment With Built-in Power Supply - High Temp Applications**

Input: Standard Remote Sensor (Variable Reluctance Pickup Coil)  
 Output: Customer Equipment, 0-20mA Sensing, Built-in Loop Power Supply

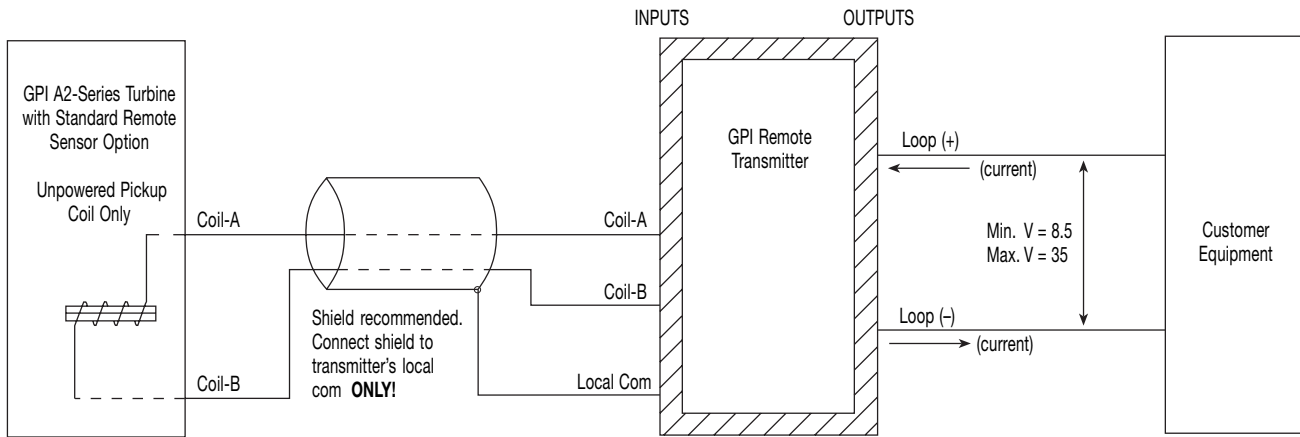

- ▶ Minimum signal amplitude required for normal operation approx. 15 mV P-P
- ▶ Recommended cable type - twisted pair with shield
- ▶ Recommended maximum cable length - 20 ft.

**CAUTION:** When reassembling the faceplate, make sure that the enclosure seal is not crimped or twisted. Do not over-tighten corner screws (hand tighten only). Faceplate can be rotated 90°.

**WIRING DIAGRAM 3**

**— 4-20mA or 0-20mA Output —**

**Customer Equipment Without Built-in Power Supply**

Input: Turbine Mounted Display or Conditioned Signal Sensor (See inputs from Diagram 1) Standard Remote Sensor (See inputs from Diagram 2)  
 Output: Customer Equipment, 0-20mA Sensing, Separate Power Supply

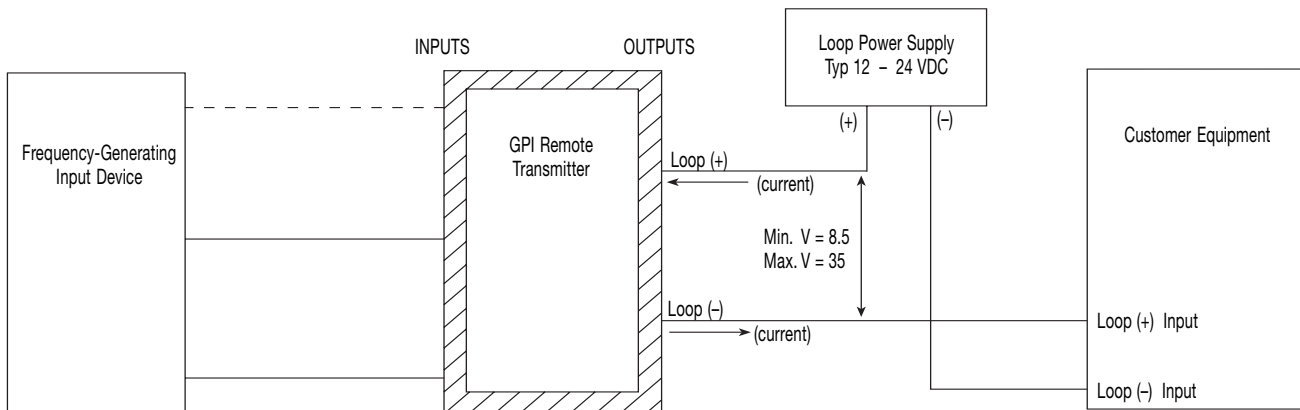

**NOTE:** Minimum loop power supply voltage required:  
 $8.5V + (\text{Max} - \text{Customer} - \text{Equipment} - \text{Drop}) + (\text{Wiring} - \text{IR} - \text{Drop})$

**CAUTION:** When reassembling the faceplate, make sure that the enclosure seal is not crimped or twisted. Do not over-tighten corner screws (hand tighten only). Faceplate can be rotated 90°.

**WIRING DIAGRAM 4**

**— 0-5 V Output —**

**Customer Equipment Without Built-in Power Supply**

Input: Turbine Mounted Display or Conditioned Signal Sensor (See inputs from Diagram 1) Standard Remote Sensor (See inputs from Diagram 2)  
 Output: Customer Equipment, 0-5 V Sensing, Separate Loop Power Supply

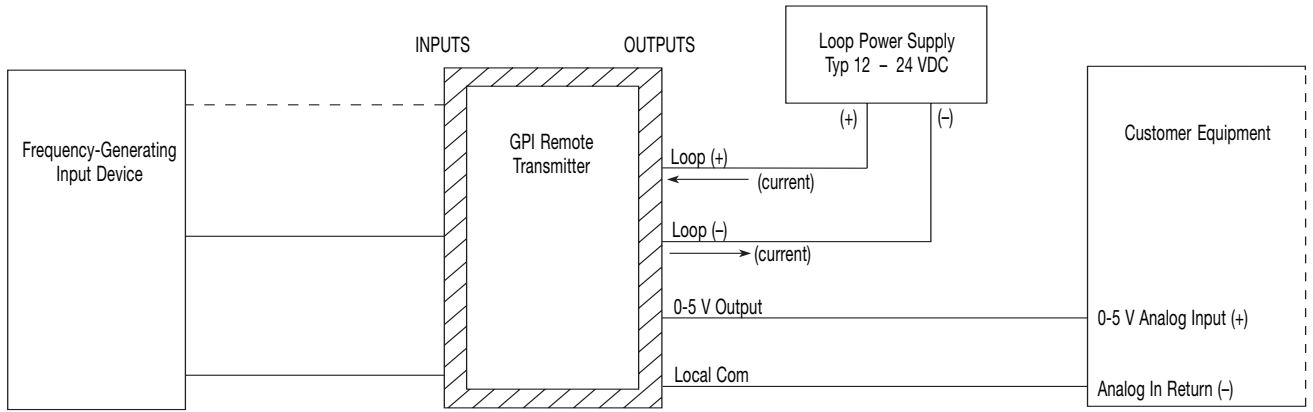

NOTE 1: Loop power supply electrically isolated from customer equipment  
 NOTE 2: Actual value of loop current (mA) is disregarded

**CAUTION:** When reassembling the faceplate, make sure that the enclosure seal is not crimped or twisted. Do not over-tighten corner screws (hand tighten only). Faceplate can be rotated 90°.

**WIRING DIAGRAM 5**

**— Pulse Output —**

**Customer Equipment Without Built-in Power Supply**

Input: Turbine Mounted Display or Conditioned Signal Sensor (See inputs from Diagram 1) Standard Remote Sensor (See inputs from Diagram 2)  
 Output: Customer Equipment, Frequency Sensing, Separate Loop Power Supply

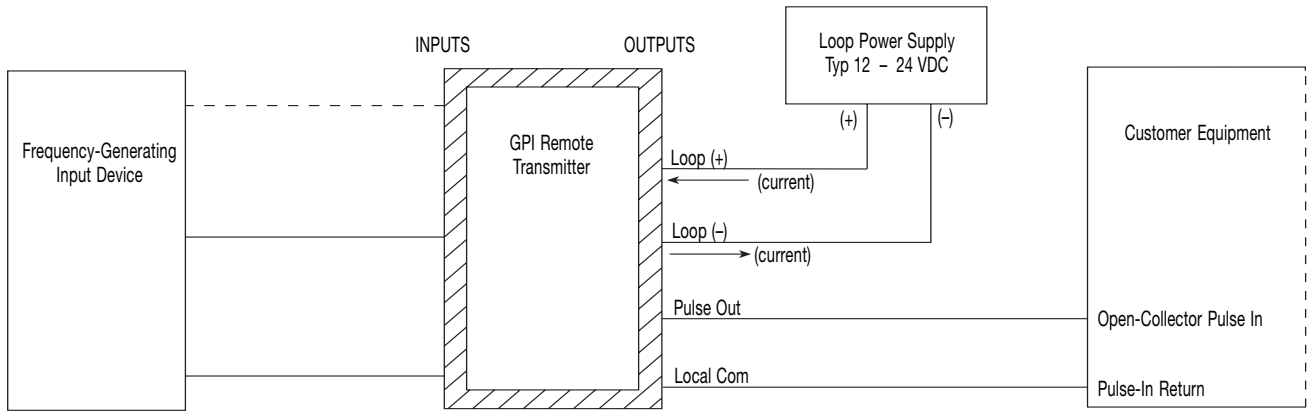

NOTE 1: Loop power supply electrically isolated from customer equipment  
 NOTE 2: Actual value of loop current (mA) is disregarded

**CAUTION:** When reassembling the faceplate, make sure that the enclosure seal is not crimped or twisted. Do not over-tighten corner screws (hand tighten only). Faceplate can be rotated 90°.

## OPERATIONS

### Setting 4-20mA Endpoints

The 4-20mA endpoint settings are independent from the meter calibration. If you reset the response time (procedure detailed below) you **MUST** reset the 4-20mA endpoints.

All units are shipped with the following items preset:

- 4mA setpoint = 50Hz
- 20mA setpoint = 100Hz
- Response Time = 0.7 second

Any new values you set for these items are automatically saved when the transmitter is powered down, and automatically restored the next time power is applied.

### Procedure

Before you start, the fluid pumping system should be ready to make two simple calibrating runs, first at the lowest anticipated flowrate, and then the second at the highest anticipated flowrate. For best accuracy, you should include a separate flowrate indicating meter, such as an appropriate GPI model, in the fluid flow path. Position yourself so you can easily operate the transmitter's pushbuttons. You should be able to see the indicator light (the small window beside the "4" button).

### Setting the Low (4mA) Endpoint:

1. Start the fluid pumping system. Set it for steady flow at the lowest anticipated rate (or the rate at which you want a "minimum" indication).
2. Wait while the fluid flow is uninterrupted for at least 10 seconds.
3. While watching the transmitter's indicating light, press and hold both its "SET" and "4" buttons. Release them when the light blinks.

**NOTE:** The length of time between "button press" and "light blink" depends on the transmitter response time. The maximum is 5 seconds. If you can't see the indicator light (if you're outdoors in bright light), you can safely just count to 5 while holding the pushbuttons.

**NOTE:** After setting the minimum, the loop current should be registering at or near 4mA. Don't worry if it's not exact, it will be correct after setting the high (20mA) endpoint.

### Setting the High (20mA) Endpoint

1. Start the fluid pumping system. Set it for steady flow at the highest anticipated rate (or the rate at which you want a "maximum" indication).
2. Wait while the fluid flow is uninterrupted for at least 10 seconds.

**NOTE:** If you observe the current loop after completing the procedure, it should be registering at or very near 20mA (within the resolution specifications for the present conditions).

3. While watching the transmitter's indicating light, press and hold both its "SET" and "20" buttons. Release them when the light blinks.

**NOTE:** During the high and low setpoint procedure, if the new settings are very different from the previous settings, it is possible to reverse the 4mA and 20mA setpoints so that the 4mA frequency is **higher** than the 20mA frequency. The situation corrects itself after you complete both setpoints. If the new settings are close to the previous settings, you may safely set either the low and high settings independently.

### Optional 0-20mA Mode

A few current loop systems use 0-20mA output. The input signal frequency of "0" produces an output analog signal of "0" with direct proportionality and no offset.

**NOTE:** A true loop current of "0" in a loop powered device like the GPI transmitter is not obtainable. That's because the current loop powers the transmitter, and its operating current is non-zero even at zero frequency input. In 0-20 mode, the GPI Remote Transmitter's loop current will drop to as near zero as possible at zero input, in most units between 1 and 2 mA.

### Procedure

1. To enter 0-20 mode, simply press and hold all three pushbuttons simultaneously (4, SET, and 20) at any flow-rate. Continue holding until the indicator light blinks (light will blink in up to 5 seconds) and release all buttons. This sets the LOW END calibration point to zero/zero.
2. Set the 20ma endpoint as described above under 4-20mA calibration.
3. The special 0-20 mode will remain in effect until a new 4mA endpoint is established in the usual way.

### Auxiliary 0-5 VDC

The Remote Transmitter is equipped with an auxiliary voltage output with a range of 0-5 VDC. This signal is capable of dropping to within a few millivolts of zero, and thus may be more suitable for use in the 0-20 mode.

No special equipment is required to use the 0-5V output, but wiring to customer equipment is different (see Wiring Diagram 4).

### Changing Response Time

The Remote Transmitter comes from the factory with a default 0.7 second response time. This should provide good performance with all GPI A2 meters.

## WARNING

If you reset the response time (procedure detailed below) you **MUST** then reset the 4-20mA endpoints.

To give good performance with a variety of sensor types, many frequency-to-analog converters, including the GPI Remote Transmitter, offer two or more settings for “response time” (sometimes referred to as “setting time, or “averaging time”).

- Longer (slower) response times are needed for sensor types that generate very low frequency outputs (like oval gear flowmeters).
- Shorter (faster) response times are preferable for sensors that generate higher frequency outputs (GPI meters, for example).
- Longer (slower) response times are also appropriate in situations where sensor-output frequency fluctuates or wobbles substantially.

The GPI Remote Transmitter offers a choice of five response-time settings, selectable by the unit’s pushbuttons.

### Procedure

1. Start with the transmitter unpowered. If the transmitter is presently operating, temporarily disable its external power supply. Be sure to allow at least 30 seconds to elapse with unit unpowered.
2. Press and hold the “4” button. While holding, watch the indicator light and power up the transmitter.
3. Shortly after power is applied, the light will blink one or more times. Count the number of blinks (from 1 to 5 blinks) and release the button after the blinking has finished.

**NOTE:** If necessary, repeat steps 1 through 3 to get the number of blinks corresponding to the response time you want.

<u>Blinks</u>	<u>Response Time</u>
1 blink	0.3 second
2 blinks	0.7 second
3 blinks	1.3 second
4 blinks	2.6 second
5 blinks	5.2 second

In normal operation, the transmitter always averages two sequential input readings. The time delay from an abrupt change in input frequency to a final, stabilized output reading is always twice that shown in the above table.

Check cable-entry seals periodically. Tighten and/or apply sealant if needed. This is especially important in environments containing heavy concentrations of dust, oil mist, or other residue.

Check all wiring connections occasionally for oxidation or corrosion. Clean and re-seat if such conditions are noted.

If necessary, check and re-seat any connections that may have been subjected to strain (during rework or construction, for example).

## TROUBLESHOOTING

SYMPTOM	PROBABLE CAUSE	CORRECTIVE ACTION
A. LOOP OUTPUT "STUCK" AT ZERO (No reading at all, regardless of input signal.)	<ol style="list-style-type: none"> <li>1. Loop not supplying power.</li> <li>2. Loop connections bad.</li> <li>3. Transmitter is faulty.</li> </ol>	<p>Be sure loop power supply is present and working, and has correct polarity.</p> <p>Check all loop connections for open- or short-circuits.</p> <p>Replace transmitter.</p>
B. LOOP OUTPUT "STUCK" AT LOW VALUE (Between 1 and 4 mA) REGARDLESS OF INPUT SIGNAL	<ol style="list-style-type: none"> <li>1. 4mA / 20mA setpoints bad or not set.</li> <li>2. No input signal.</li> <li>3. Input connections bad.</li> <li>4. Transmitter is faulty.</li> </ol>	<p>Perform new setpoint procedure for both 4mA and 20mA points.</p> <p>Verify presence of input signal at terminal block.</p> <p>Check all signal-input connections for open- or short-circuits.</p> <p>Replace transmitter.</p>
C. LOOP OUTPUT "STUCK" AT FULL-SCALE (above 20mA) REGARDLESS OF INPUT SIGNAL	<ol style="list-style-type: none"> <li>1. 4mA / 20mA setpoints bad or not set.</li> <li>2. Short-circuit between Loop (-) and LOCAL-COM circuits.</li> </ol>	<p>Perform new setpoint procedure for both 4mA and 20mA points.</p> <p>Check all Loop and LOCAL-COM circuitry for shorts.</p>
D. LOOP OUTPUT WITHIN NORMAL RANGE, BUT INCORRECT	<ol style="list-style-type: none"> <li>1. 4mA / 20mA setpoints bad or not set.</li> </ol>	<p>Perform new setpoint procedure for both 4mA and 20mA</p>
E. LOOP OUTPUT "BOUNCES" ERRATICALLY (is unstable)	<ol style="list-style-type: none"> <li>1. Output response-time setting too short, especially for slow input signal.</li> <li>2. Input connections bad.</li> </ol>	<p>Select a longer response-time setting.</p> <p>Check all signal-input connections for intermittent open- or short-circuits.</p>
F. LOOP-OUTPUT STABLE BUT RESPONSE TIME TOO SLOW	<ol style="list-style-type: none"> <li>1. Output response-time setting too long, especially for fast input signal.</li> </ol>	<p>Select a shorter response-time setting.</p>
G. LOOP-OUTPUT OK, BUT 0-5 V OUTPUT DOESN'T WORK	<ol style="list-style-type: none"> <li>1. 0-5 V output loaded too heavily.</li> </ol>	<p>Be sure 0-5 V load impedance is at least 1000 ohms (1K<math>\Omega</math>).</p>
H. LOOP AND 0-5V OUTPUTS OK, BUT OPEN-COLLECTOR PULSE-OUT OUTPUT DOESN'T WORK	<ol style="list-style-type: none"> <li>1. No pull-up resistor or pull-up power.</li> </ol>	<p>Be sure pull-up resistor and pull-up power present, with correct polarity.</p>

# DIMENSIONS

## PIPE MOUNT DIMENSIONS

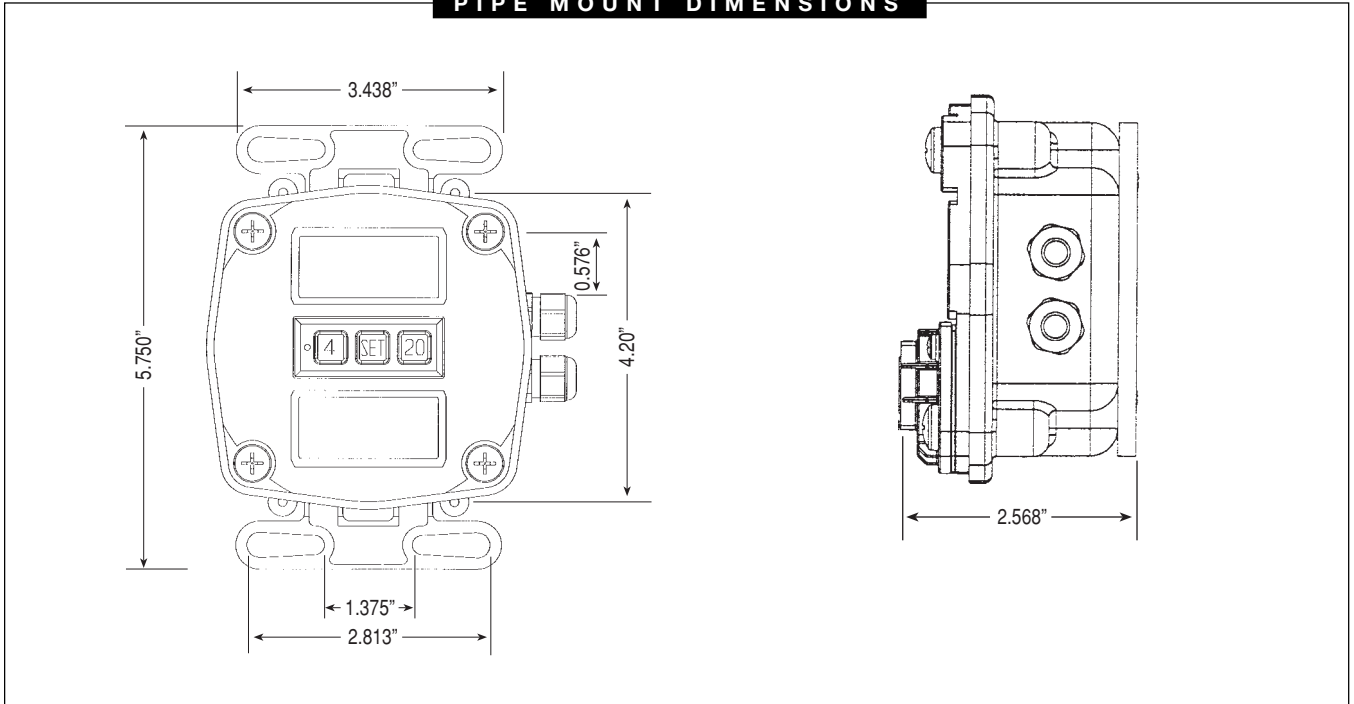

## WALL MOUNT DIMENSIONS

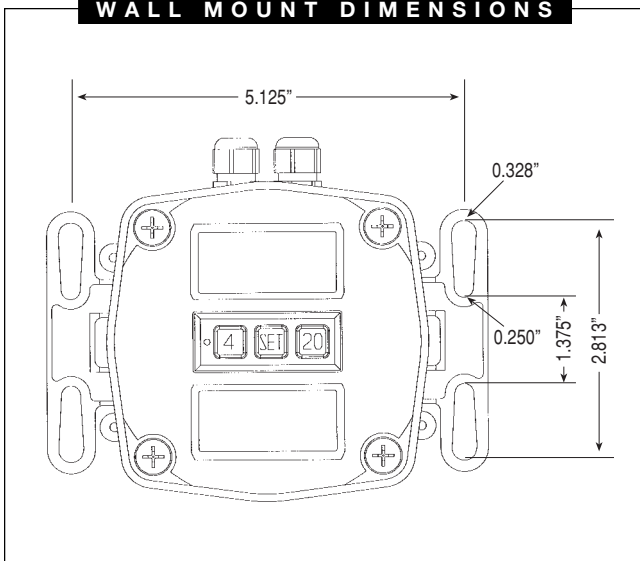

## PANEL CUT-OUT DIMENSIONS

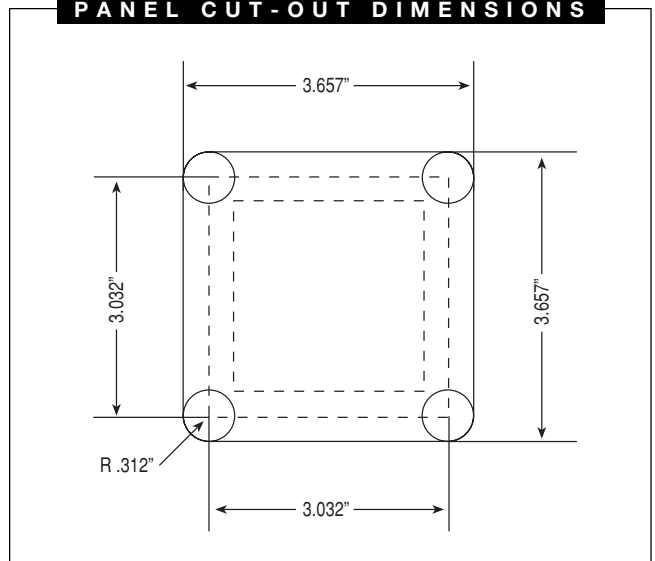

## SPECIFICATIONS

### Mechanical:

Enclosure:	Equiv. to NEMA 4/IP65
Strain Relief:	Hubble PG7 Grip range 0.11-0.26
Strain Relief Thread:	Female 1/2-20 UNF-2B
Cable:	Belden 9363 (22AWG-2 conductor w/drain wire and shield)
Cable Length:	20 ft (6m) provided
Operation Temperature:	+14°F to 140°F (-10°C to 60°C)
Storage Temperature (with display):	-40°F to 158°F (-40°C to 70°C)

### Power Supply:

Type:	2-wire system - Loop powered w/reverse polarity protection
Voltage Requirement:	
Minimum:	8.5 VDC
Maximum:	35 VDC (higher voltage may damage unit)

### Primary Output (4-20mA or 0-20mA):

Type:	Loop
-------	------

### Auxiliary Outputs:

#### 0-5 V

Type:	Single-ended
-------	--------------

#### Pulse-Out

Type:	Open collector NPN (current sinking)
Max. "OFF" voltage:	60 V
Max. "ON" current:	200 mA
Max. "ON" voltage drop:	< 0.5V @ 200mA

#### EDM-Pwr

Type:	Can supply regulated 5 VDC at up to 2.5mA to external circuitry
-------	---

### Sensor Options

#### (For use with GPI A2 Turbine Meters)

#### Turbine Mounted Display Option:

Output Type:	Open Collector
Sensor to Transmitter Distance:	25 ft. (Can reach up to 250 ft. with addition of customer-supplied pull-up resistor and 5,000 ft. with addition of customer-supplied pull-up resistor and external power source)

#### Standard Remote Sensor Option:

Output Type:	Low Level Sine Wave Use with Low or High Temperature liquids -40°F to 250°F (-40°C to 121°C)
Sensor to Transmitter Distance:	Up to 20 ft.

### Frequency Inputs (Remote Display):

Low Level Coil (LLC):	Frequency Range 0-1000 Hz (waveform dependent)
High-Level Low Frequency (HLLF):	Frequency Range 0-150 Hz (debounced, waveform dependent)
High Level High Frequency (HLHF):	Frequency Range 0-1200 Hz (not debounced, requires clean logic level square or rectangular waveform)
Optically isolated HLLF:	Same as HLLF with 2500 V optical isolation
Optically isolated HLHF:	Same as HLHF with 2500 V optical isolation

NOTE: GPI A2 Turbine Meter Sensors use High Level High Frequency (HLHF) input. For other sensor types, call GPI Customer Support for technical specifications.

### Performance:

Max. Conversion Error:	(nonlinearity plus span, any input, loop-current output, 0°C to 70°C, loop voltage supply 12 VDC to 24 VDC) 0.5% of span plus possible resolution uncertainty.
Max. Conversion-Resolution Uncertainty:	(Loop-current output, when properly calibrated) Larger of 0.1 mA or $[20 \text{ mA} / (10 \times (f_{20} - f_4))]$ . Where $f_{20}$ = frequency at 20 mA, $f_4$ = frequency at 4 mA.
Speed of Response:	After step change in input frequency, loop output guaranteed stable within 3 x accumulating-time (Accumulating-time user selectable from 0.3 sec, 0.7 sec, 1.3 sec, 2.6 sec, 5.2 sec).

## PARTS LIST

<b>Part No.</b>	<b>Description</b>
120048-01	Gasket
120058-01	Bracket
120509-01	Adapter Kit
120510-01	Circuit Kit (Main)
120512-01	Switch Keypad Kit (Small Cover)
120513-01	Strain Relief Kit
125066-3	Cable, 100 feet
125066-20	Cable, 20 feet
901002-82	O-Ring
904005-27	Sems Screw and Washer (2 ea. required)
904005-28	Sealing Screw (4 ea. required)

## SERVICE

For warranty consideration, parts, or other service information, please contact your local distributor. If you need further assistance, contact the GPI Customer Service Department in Wichita, Kansas, during normal business hours.

**Tel: 316-686-7361**  
**Fax: 316-686-6746**

To obtain prompt, efficient service, always be prepared with the following information:

- The model number
- The manufacturing date code

The date code is a four-digit number (XXXX) located under the coverplate.

For warranty work, always be prepared with your original sales slip or other evidence of purchase date.

Please contact GPI before returning any part. It may be possible to diagnose the trouble and find a solution with a telephone call. GPI can also inform you of any special requirements you will need to follow for shipping.

**SAVE THESE INSTRUCTIONS**

## Limited Warranty Policy

Great Plains Industries, Inc. 5252 E. 36<sup>th</sup> Street North, Wichita, KS USA 67220-3205, hereby provides a limited **one year warranty** against defects in material and workmanship on all products manufactured by Great Plains Industries, Inc. except models BP-10, BP-12, LP-50, RP-5 and CP-5. These models carry a 90-day warranty. The warranty shall extend to the purchaser of this product and to any person to whom such product is transferred during the warranty period.

The warranty period shall begin on the date of the original new equipment purchase. Warrantor's obligation hereunder shall be limited to repairing defective workmanship or replacing or repairing any defective part or parts. This warranty shall not apply if:

- A. the product has been altered or modified outside the warrantor's duly appointed representative;
- B. the product has been subjected to neglect, misuse, abuse or damage or has been installed or operated other than in accordance with the manufacturer's operating instructions.

To make a claim against this warranty, notice of claim must be given in writing to the company at its above address no later than 30 days after the expiration of the warranty period. Such notice shall identify the defect in the product. The company shall, within 14 days of receipt of such notice, notify the customer to either send the product, transportation prepaid, to the company at its office in Wichita, Kansas, or to duly authorized service center. The company shall perform all obligations imposed on it by the terms of this warranty within 60 days of receipt of the defective product.

GREAT PLAINS INDUSTRIES, INC. EXCLUDES LIABILITY UNDER THIS WARRANTY FOR DIRECT, INDIRECT, INCIDENTAL AND CONSEQUENTIAL DAMAGES INCURRED IN THE USE OR LOSS OF USE OF THE PRODUCT WARRANTED HEREUNDER.

The company herewith expressly disclaims any warranty of merchantability or fitness for any particular purpose other than for which it was designed.

This warranty gives you specific rights and you may also have other rights which vary from U.S. state to U.S. state.

Note: In compliance with MAGNUSON MOSS CONSUMER WARRANTY ACT – Part 702 (governs the resale availability of the warranty terms).



5252 East 36th Street North  
Wichita, KS USA 67220-3205  
TEL: 316-686-7361  
FAX: 316-686-6746

***GREAT PLAINS INDUSTRIES, INC.***

*"A Great Plains Ventures Subsidiary"*

www.gpi.net

**1-888-996-3837**