

# **Blancett<sup>®</sup>**

**Flow Meters**

## **B2800 FLOW MONITOR**

### **Explosion Proof**

**Programming and Installation Manual**

**Advanced - Version 1.01**



Division of Racine Federated Inc.  
100 East Felix Street South, Suite 190 Fort Worth, Texas 76115  
Tel: 817-920-9998 • Fax: 817-921-5282 • Toll-Free: 800-235-1638

## Contents

|  |       |
|--|-------|
| Introduction.....                        | 2     |
| Specifications.....                      | 3     |
| Operating the Monitor.....               | 4     |
| Programming.....                         | 4-6   |
| Programming Flowchart.....               | 14-15 |
| Additional Scaling Parameters.....       | 7-9   |
| Wiring Diagram.....                      | 10    |
| Enclosure Installation.....              | 12-13 |
| Troubleshooting.....                     | 16    |
| General Notes on Scaling.....            | 17-18 |
| Blancett Part Numbering Information..... | 19    |

## Symbol Explanation



**This symbol appears in this manual to call special attention to instructions that affect the safe installation, function, and use of this product. Any use of this product in a manner not specified by the manufacturer may be dangerous and will void the manufacturer's warranty. Whenever this symbol appears please refer to accompanying documentation.**

**Notice: Blancett reserves the right to make any changes or improvements to the product described in this manual at any time without notice.**

**The B2800 Flow Monitor** is a state-of-the-art, microprocessor based flow monitor, designed to provide the user with exceptional flexibility at a very affordable price. Though designed for use with Blancett Flow Meters, this display can be used with almost any flow meter producing a low amplitude AC output or contact closure signal(s).

### Features

- Displays Rate and/or Total
- Large 0.5 Inch, 8 Digit Display for Easy Viewing
- 10 Point Linearization Capability
- Microprocessor Based, Low Power Components
- 2 Power Options – 1.5V D' Size Battery or 4-20mA Loop
- Surface Mount Technology Use Throughout



**Danger:** Do not open explosion proof enclosure unless the area is known to be free of hazards. Failure to make the area safe before opening the enclosure can result in a hazardous situation with a potential for injury.

This flow monitor is capable of accepting a low-level frequency input for calculating flow rate and total. These calculations can then be displayed in the desired units of measurement. All B2800 flow monitors come pre-calibrated, from the factory, if ordered with a Blancett Flow Meter. If required, however, it can easily be re-configured in the field. The monitor's large 8 digit by .5" numeric liquid crystal display makes extended range viewing practical. The second 8 digit by .25" alphanumeric display provides for selectable units viewing in run mode and prompts for variables in programming mode. Finally, the user can choose between displaying rate, total, or alternating between both rate and total.

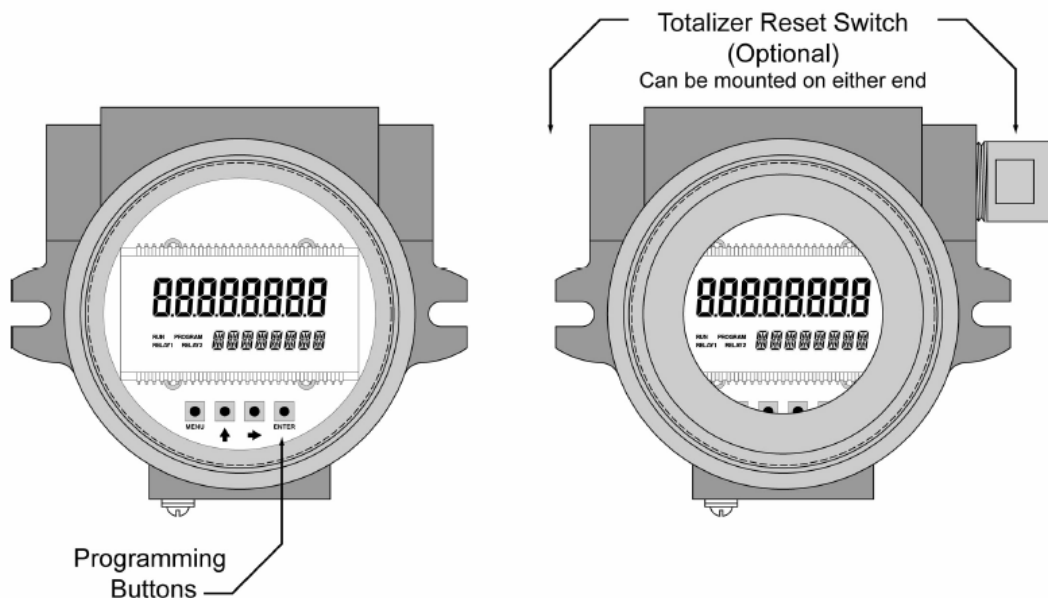

## Specifications

|  |  |
|--|--|
| <b>Power Supply Options:</b>   |  |
| <b>Battery Powered</b>   | 1 D" size 1.5 Volt Alkaline Battery  |
| <b>Loop Powered</b>  | 4-20 mA Loop Powered   |
| <b>Power Consumption:</b>  |  |
| <b>Battery Powered</b>   | Less than 1 milli-watt   |
| <b>Loop Powered</b>  | 25mA (Maximum)   |
| <b>Alpha-Numeric Rate and Totalization Display:</b>                              | 8 digit, .5" high numeric display<br>8 character, .25" high alphanumeric display   |
| <b>Pulsed Output Signal:</b>   |  |
| Outputs one pulse for each increment of the least significant digit of totalizer |  |
| Pulse Type:  | Opto-Isolated open collector Transistor  |
| Max. Voltage:  | 30V DC   |
| Pulse Width ON State:  | 20mS/ Max pulse rate 25Hz  |
| Current (ON State):  | 0.9V drop @ 5.0mA or 0.7V drop @ 0.1A  |
| <b>Inputs:</b>   |  |
| Magnetic Pickup Input:   |  |
| Frequency Range:   | 0 to 3500 Hz   |
| Trigger Sensitivity:   | 30mV p-p   |
| Over Voltage Protected:  | ±30V DC  |
| <b>Frequency Measurement Accuracy:</b>   | ±0.1%  |
| <b>Temperature Drift:</b>  | 50 ppm / °C (Max)  |
| <b>Analog Output (Loop Powered Version):</b>                                     | 4-20mA Current Loop  |
| Resolution:  | 1:4000   |
| <b>Transient Overvoltages:</b>   | Category 3, accordance with IEC664   |
| <b>Pollution Degree:</b>   | 2, in accordance with IEC664   |
| <b>Mounting Classification:</b>  | NEMA/UL/CSA Type 4 (IP66)  |
| <b>Environmental:</b>  |  |
| Operating Temperature:   | -22 °F (-30 °C) to 158 °F (70 °C)  |
| Humidity:  | 0-90% Non-condensing   |
| <b>Certifications:</b>   |  |
| CSA Ordinary Locations :   | To: C22.2 No. 1010-1 for Canada<br>ISA S82.02 for US   |
| CSA Hazardous Locations :  | For: Class I, Div I, Groups B, C, D<br>Class II, Groups E, F, G<br>Class III; Type 4X; T6 @ 70°C<br>To: C22.2 No. 30 for Canada<br>FM3615 for US |
| <b>Units of Measure:</b>   | Gallons, Oil Barrels, Liters, Cubic Meters, MGal, Cubic FT, MLiters, Acre FT, Liq. Barrels, LBS, KGS   |
| <b>Time Intervals:</b>   | Day, Hour, Minute, Second  |

## Operating the Monitor

The monitor has two modes of operation referred to as the **RUN** mode and the **PROGRAM** mode. Both the run mode and the program mode display screen enunciators confirming the state of the monitor. A quick glance at the lower left hand corner of the LCD screen will confirm operating status. Normal operation will be in the run mode. To access the programming mode, press the **MENU** button until the first programming screen is displayed. After programming the display with the necessary information, a lock out feature can be turned on to prevent unauthorized access or changing the meter's setup parameters.

### Advanced Programming Mode

Keys:

**MENU** – Switches between RUN and PROGRAMMING modes.

**UP** Arrow – Scrolls through programming sub-menus in forward directing and increments numeric variables.

**RIGHT** Arrow – Scrolls through programming sub-menus in reverse direction and moves the active digit to the right.

**ENTER** – Used to enter sub-menus, save programming information and in the reset process.

If your monitor was ordered with a Blancett flow meter, the two components ship from the factory, calibrated as a set. If the monitor is a replacement, the turbine's K-Factor has changed, or the monitor is being used with some other pulse generating device, programming will be necessary.

### Programming Using Pulse Output Turbine Flow Meters

Each turbine flow meter is shipped with either a K-Factor value or frequency data. If frequency data is provided, the data must be converted to a K-Factor before programming; otherwise, 10 Point Linearization must be used to program the monitor. (See "General Notes on Scaling" at the end of this manual). K-Factor information, when supplied, can usually be found on the neck of the flow meter or stamped on the body. The K-Factor represents the number of pulses per unit of volume. The K-Factor will be needed to program the monitor readout.

**Enter Programming Mode** – Change to programming mode by pressing the MENU button once. The mode indicator will change from RUN to PROGRAM.

**Note:** If any input value exceeds the meters capabilities for that particular parameter the LIMIT indicator will begin to flash indicating an invalid entry. Press ENTER once to return to the parameter's entry screen to reenter the value.

**Select The Meter Size** – At the METER prompt, press the ENTER button once. The current meter size number will begin to flash. Using the arrow keys, scroll through the size choices until you find the bore size of your meter. Press ENTER once to save the meter size choice.

**Note:** The meter connection size and the bore size are different. For example, many of the 1" NPT turbines have bore sizes that range from 3/8" up 1". Be sure to use the correct bore size or the meter could report incorrect flows and totals.

**Select the Display Function** – The monitor can display RATE or TOTAL or alternate between BOTH rate and total. At the DISPLAY prompt, press the ENTER key once. The monitor now shows the display mode currently in effect. If the current selection is correct, press the ENTER key to advance to the next parameter. To change to an alternate display mode, use the arrow keys to scroll to the desired display mode and press ENTER to save the choice.

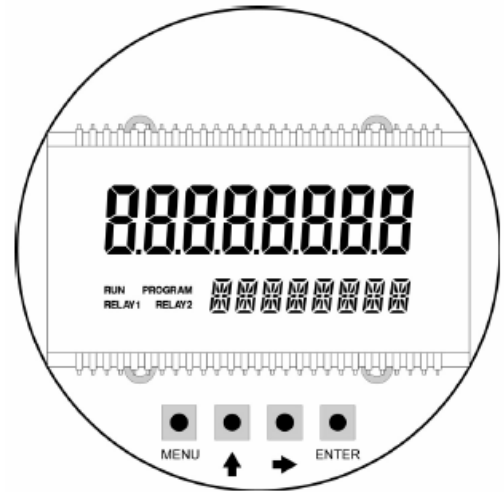

**FIGURE 1 - FRONT PANEL**

**Select the Rate Units of Measure** – The monitor allows the choice of many common rate units. (See the specifications for a complete listing of the unit choices.) At the RATE UNT prompt, press the ENTER key once. The monitor now shows the rate units of measure the display is currently set for. If the current selection is correct, press the ENTER key to advance to the next parameter. To change to an alternate unit, use the arrow keys to scroll to the desired rate unit and press ENTER to save the choice.

**Select the Rate [Time] Interval** – The term Rate implies that something is occurring over a period of time. Most people are familiar with the rate of speed of a car reported in miles per hour (MPH). The same concept holds true for a flow meter. The time choices are SEC (seconds), MIN (minutes), HOUR (hours), and DAY (days). At the RATE INT prompt, press the ENTER key once. The monitor now shows the time interval the display is currently set for. If the current selection is correct, press the ENTER key to advance to the next parameter. To change to an alternate time interval, use the arrow keys to scroll to the desired time interval and press ENTER to save the choice.

**Note:** If flow rate is the only measurement of interest, skip top KFAC UNT to complete the programming process.

**Select the Total Units of Measure** – If a flow amount is desirable, the units for the total must first be chosen. The monitor allows the choice of many common totalization units. (See the specifications for a complete listing.) At the TOTL UNT prompt, press the ENTER key once. The monitor now shows the total units of measure the display is currently set for. If the current selection is correct, press the ENTER key to advance to the next parameter. To change to an alternate unit, use the arrow keys to scroll to the desired totalization unit and press ENTER to save the choice. **Note:** This unit of measure does not have to reflect the rate unit you have previously chosen. (Example: Rate Units = Gallons, Total Units = Barrels).

**Select the Total's Display Multiplier** – The monitor has a very versatile display that has the ability to accumulate the flow total in multiples of ten. For example, if the most desirable totalization unit is 1,000 gallons, the monitor can easily be set up for this requirement. Once the unit is back in RUN mode, every time the total display is incremented by one digit the actual total would be an additional 1,000 gallons. At 1,000 gallons the total display would read 1, at 3,000 gallons the total display would read 3, etc. This feature eliminates having to look at a total, counting the digits and mentally inserting commas for each 1000 multiple.

At the TOTL MUL [Multiple] prompt, press the ENTER key once. The monitor now shows the multiplier the total display is currently set for. If the current selection is correct, press the ENTER key to advance to the next parameter. To change to an alternate multiplier, use the arrow keys to scroll to the desired multiplier unit and press ENTER to save the choice.

**Multiplier Choices** – 0.01, 0.1, 1, 10, 100, 1000, 10000, 100000, and 1000000 Units

**Enter the Meter's K-Factor Unit** – At the KFAC UNT prompt, press the ENTER key once. The display now shows the current K-Factor unit. If the current selection is correct, press the ENTER key to advance to the next parameter. For meters calibrated in gallons use PUL/GAL. For meters calibrated in cubic meters use PUL/M3 (pulses per cubic meter). **Note: Unless otherwise specified, turbine flow meters are supplied with K-Factors measured in pulses per gallon (PUL/GAL).** To change to an alternate K-Factor unit, use the arrow keys to scroll to the desired K-Factor unit and press the ENTER key to save your choice.

**Enter the Meter's K-Factor** – (Note: The K-Factor supplied with your meter or calculated from calibration data will be needed to complete this step.) At the K FACTOR prompt, press the ENTER key once. The most significant digit in the K-Factor will begin to flash. Using the arrow key, increment the display digit until it matches the meter's K-Factor digit. If the current selection is correct, press the arrow key to advance to the next digit. Repeat this process until all K-Factor digits have been entered. Press ENTER once to save the K-Factor.

Congratulations, this completes the basic monitor programming. Press the MENU key twice to return to the RUN mode. To continue with the advanced programming menu, continue to the "Additional Scaling Parameters" section on the next page.

## Additional Scaling Parameters

**Note:** Some of the following scaling parameters are model dependent and may not be displayed.

**Scale Factor** – At the SCALE F prompt, press the ENTER key once. The current Scale Factor will begin to flash. If the current selection is correct, press the ENTER key to advance to the next parameter. The scale factor is used to force a global change to all variables. For example, under operating conditions the display is reading a consistent 3% below the expected values at all flow rates. Rather than changing all parameters individually, the scale factor can be used to compensate for the 3% offset. The scale factor would be set to 1.03 to correct the readings. The range of scale factors is from 0.5 to 1.5. The default scale factor is 1.00.

**Damping Factor** – At the DAMPING prompt, press the ENTER key once. The current Damping setting will begin to flash. If the current selection is correct, press the ENTER key to advance to the next parameter. The Damping Factor is increased to enhance the stability of the flow readings. Damping values are decreased to allow the flow meter to react faster to changing values of flow. This parameter can take on any value between 0 and 99 with 0 being the default.

**Totalizer Pulse Output** – The pulse output parameter can be either enabled or disabled. When enabled this output generates 20mS duration pulse for every time the least significant digit of the totalizer increments. The amplitude of the pulse is dependent on the voltage level of the supply connected to the pulse output and is limited to a maximum 30 VDC.

**Flow 4mA Setting** – When the loop powered option is ordered, the flow rate that corresponds to 4mA must be set. If the current selection is correct, press the arrow key once to advance to the next parameter. If adjustment is required, press the ENTER key once at the FLOW 4MA prompt. The most significant digit will begin to flash. The arrow key moves the active digit one place to the right for each press of the key. The arrow key increments the active digit one integer for each press of the key. When the correct 4mA flow rate has been entered, press ENTER once to store this value and move to the next parameter.

**Flow 20mA Setting** – Follow the same programming procedure as the FLOW 4MA except for the flow rate setting. In this case, the maximum rate of flow for the meter should be used.

**4-20mA Calibration** – When ordered with a 4-20mA output option, this menu item allows the fine adjustment of the 4-20mA output. The 4mA setting is typically between 35 and 50. To set the 4mA value, connect an ammeter in series with the loop power supply. At the 4-20CAL prompt, press ENTER once. This display will now show a steady NO indication. Press the arrow key to change to a flashing YES display. Press ENTER once to access the 4mA fine adjustment.

**4mA Adjustment** – While monitoring the ammeter, adjust the 4mA value to obtain a 4mA reading. The  $\rightarrow$  arrow key increments the value and the  $\leftarrow$  arrow key decrements the value. When a steady 4mA reading is obtained on the ammeter, press the ENTER key to lock in this value and move to the 20mA adjustment.

**20mA Adjustment** – The 20mA adjustment is performed using the same procedure as the 4mA adjustment.

While monitoring the ammeter, adjust the 20mA value to obtain a 20mA reading. The  $\rightarrow$  arrow key increments the value and the  $\leftarrow$  arrow key decrements the value. When a steady 20mA reading is obtained on the ammeter, press the ENTER key to lock in this value and move to the next parameter.

**4-20mA Test** – The monitor contains a diagnostic routine that allows the simulation of mA values between 4 and 20 to check output tracking. At the 4-20 TEST prompt the arrow keys change the simulated mA output increments of 1mA. The ammeter should track the simulated mA output. If a 4-20mA test is not necessary, press ENTER once to move to the next parameter.

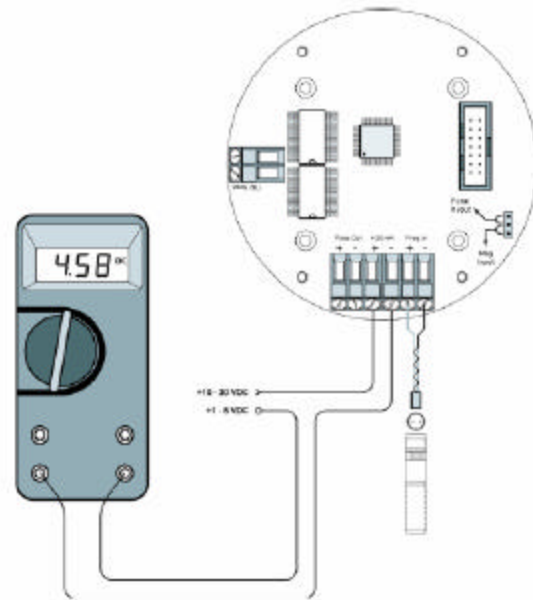

Figure 2 - Typical Ammeter Connection

**Linearization** – Enhanced accuracy can be obtained by linearization of the display. The linearization routine will accept a maximum of ten points. Linearization requires additional calibration data from the meter to be used with the monitor. Typically, calibration information can be obtained in three, five, and ten points from the flow meter's manufacturer. If linearization is not needed, pressing the  $\rightarrow$  arrow key will take you to the next parameter. (See "General Notes on Scaling" for more information).

**Number of Points** – At the LINEAR prompt, press ENTER once. The NUM PTS number will be displayed. Press ENTER to set the number of points you wish to use. Again, the  $\rightarrow$  arrow key increments the value and the  $\leftarrow$  arrow moves the cursor between digits. When the number of points has been input, press the ENTER key once to move to the first linear segment.

Press the ENTER key once and the first linear point's frequency input will begin to flash (FREQ 1). Enter the frequency for the first linear point using the arrow keys. When the frequency value input is completed, press ENTER once again to change to the coefficient value for the first linear point.

The coefficient is the value applied to the nominal K-Factor to correct it to the exact K-Factor for that point. The coefficient is calculated by dividing the actual K-Factor for that point by the average K-Factor for the flow meter.

$$\text{Coefficient} = \text{Actual K-Factor} \div \text{Average K-Factor}$$

At the COEFF prompt, enter the coefficient that corresponds to the frequency value previously entered. Press ENTER once to move to the next scaling point.

Continue entering pairs of frequency and coefficient points until all data has been entered. Press the MENU key twice at the NUM PTS prompts to exit to the LINEAR prompt. Press the  $\leftarrow$  arrow key to move to the next parameter.

**Password** – Password protection prevents unauthorized users from changing programming information. Initially, the password is set to all zeros. To change the password, press ENTER once at the password prompt. The first digit of the password value will begin to flash. Using the arrow keys as previously described, enter the password value. Pressing ENTER once will store the password and take you back to the METER size screen, pressing MENU exits the programming mode. The B2800 Flow Monitor is now ready for use with its companion meter.

**Reset Total** – To reset the monitor total display, in run mode press the MENU and ENTER simultaneously until TOTAL RST starts to flash. The TOTAL RST will stop flashing and the display will return to the run mode at the conclusion of the procedure.

**Store Total** – The current total can be manually stored in the monitor's flash memory. This procedure may be desirable prior to changing the settings or replacing the battery. Press and hold the ENTER key for 2 seconds. The display will respond with a flashing TOTALSVD and then return to the run mode.

**Automatic Store Total** – The monitor is equipped with a store total feature that works automatically, saving the current total to flash memory. The frequency of saves depends on the power supply option chosen

|                  |   |
|------------------|---|
| Battery Powered: | Once per hour and just before a low battery condition turns the unit off. |
| Loop Powered:    | Once every ten minutes.   |

## Additional Input Options

The B2800 Flow Monitor is capable of receiving Magnetic Pickup Input or a Contact Closure Input. Since most Blancett Flow Meters utilize a magnetic pickup, the monitor is shipped configured for magnetic pickup input. To change to a contact closure input, remove JP2 from the **Bottom** two pins and jumper them to the **Top** two pins.

**See Figure 3 – Circuit Board Layout.**

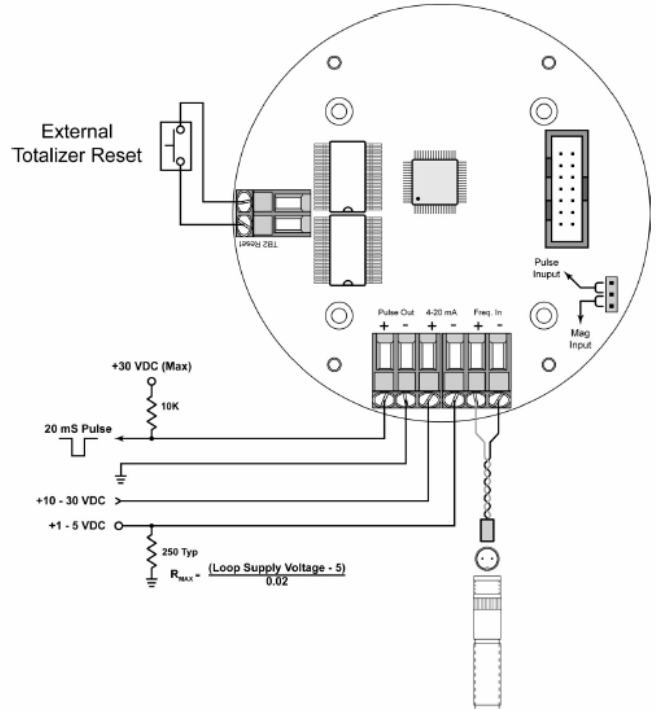
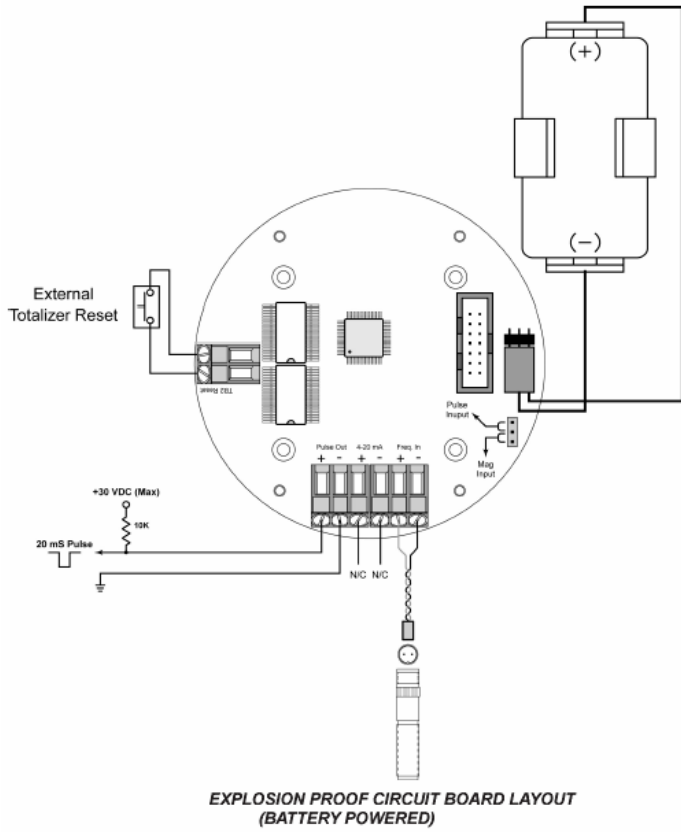

**FIGURE 3**

**EXPLOSION PROOF CIRCUIT BOARD LAYOUT  
(LOOP POWERED)**

NOTES:

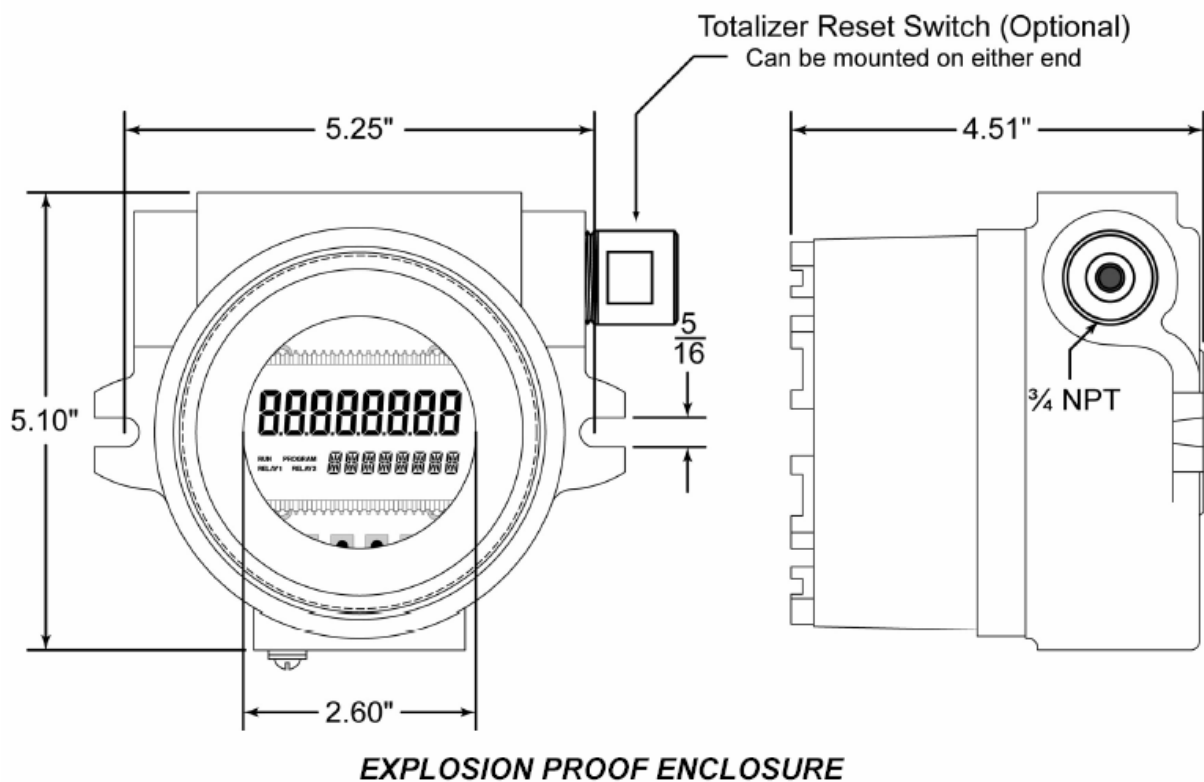

## Battery Replacement

Battery powered monitors use a single 1.5V, D size, alkaline battery. When replacement is necessary, use a clean fresh battery to insure continued trouble free operation. It is recommended that the total be saved to memory before the battery is removed. (See "Store Total" in the programming section of this manual.)

### Explosion Proof Version



**Danger:** Do not open explosion proof enclosure unless the area is known to be free of hazards. Failure to make the area safe before opening the enclosure can result in a hazardous situation with a potential for injury.

Carefully unscrew the enclosure cover to access the circuit board. Remove the four screws securing the circuit board to the enclosure. Lay the circuit board to the side being careful not to pull any wires from their connections. Clip the battery retaining wire/strap and remove the battery. Replace the battery being sure to observe the proper polarity and install a new retaining strap or wire. Reassemble the monitor reversing the disassembly process.

# Explosion Proof Enclosure Installation

The EIH Instrument Enclosure is designed to house instrumentation and control equipment as well as act as a conduit outlet body in hazardous, abusive, and wet locations.

The EIH enclosure is approved by Underwriters Laboratories Inc., Canadian Standards Association, Factory Mutual and CENELEC for use in Class I, Groups B\*, C\*\*, and D, Class II, Groups E, F, and G and Class II hazardous (classified) locations as defined by the National Electrical Code® and Canadian Electrical Code. It is also NEMA/UL/CSA Type 4 and IP66 rated for watertight applications.

*\*With conduit seals installed within 18 inches of enclosure*

*\*\*For CSA group C applications, unsealed conduit lengths must not exceed 5 ft (152 cm).*

## Installation



**WARNING** Electrical power must be “OFF” before and during installation and maintenance.

1. EIH Instrument Enclosures are furnished with ¾” NPT offset through-feed cast hubs for conduit entries. EIH Instrument Enclosures are supplied with ¾” NPT offset through-feed cast hubs on the power side and one ¾” NPT hub on the instrument side for conduit entries. (Use Crouse-Hinds RE21-SA to reduce to ½” hubs.)
2. Secure the enclosure to the conduit system. If the enclosure has mounting feet, select a mounting location that will provide sufficient strength and rigidity to support the enclosure as well as the enclosed device and wiring.



**CAUTION** Select a mounting location so that the enclosure will not be subjected to impact by heavy objects. Impacts can damage enclosed devices or glass lens.



**CAUTION** The hazardous location information specifying class and group listing of each instrument enclosure is marked on the nameplate of each enclosure.



**CAUTION** All unused conduit openings must be plugged. Plug unused conduit openings with Crouse-Hinds PLG2. Plugs must be a minimum of 1/8” thick and engage a minimum of 5 full threads.

3. Install Crouse-Hinds EYS Sealing Fittings required by Section 501-5 and/or 502-5 of the National Electrical Code® and Section 18 of the Canadian Electrical Code as well as any other applicable local codes and when enclosure is installed in Class I Group B hazardous locations. (For CSA Group C applications, unsealed conduit lengths must not exceed 5 ft. or 152 cm).
4. Un-thread instrument (and power side) covers and carefully set aside to prevent damage to the cover threads and glass lens (when glass lens cover is used).

5. Pull wires into enclosure making certain they are long enough to make the required connections and to remove the instrument or power supply if servicing is required. Install instrument and power supply, if applicable and make all electrical connections.

**NOTE:** *When installing device be sure to check instrument dimensions to avoid interference with clamping ring on glass lens and the cover on standard units.*

6. Test wiring for correctness by checking continuity and also check for unwanted grounds with insulator resistance tester. Make sure test equipment being used will not damage instrument to be housed in the EIH or EIH instrument enclosure.
7. Carefully re-thread cover to enclosure housing. Tighten cover until cover flange contacts body face.



**CAUTION** Use care to prevent dirt, grit or other foreign material from lodging on threads. If any such material settles on these threads, clean them with Kerosene or Stoddard solvent\*\*\*, then re-lubricate with Crouse-Hinds Type STL thread lubricant.

\*\*\*To avoid the possibility of an explosion, oxidation and corrosion, do not use gasoline or similar solvent.

8. Tighten cover set screws to prevent cover from loosening under vibration.



**WARNING** To maintain the explosion proof integrity of the enclosure with a screw in a tapped mounting pad hole, there must be a minimum of 1/16" of material between the drill point and the back wall. If for any reason a screw will not be threaded into the drilled hole a minimum of 1/8" of material must remain between the drill point and the back wall.

## Maintenance



**WARNING** Always disconnect primary power source before opening enclosure for inspection or service.

1. Frequent inspection should be made. A schedule for maintenance checks should be determined by the environment and frequency of use. It is recommended that it should be at least once a year.
2. Perform visual, electrical and mechanical checks on all components on a regular basis.
  - A) Visually check for undue heating evidenced by discoloration of wires or other components, damaged or worn parts, or leakage evidenced by water or corrosion in the interior.
  - B) Electrically check to make sure that all connections are clean and tight and that the device is operating correctly.

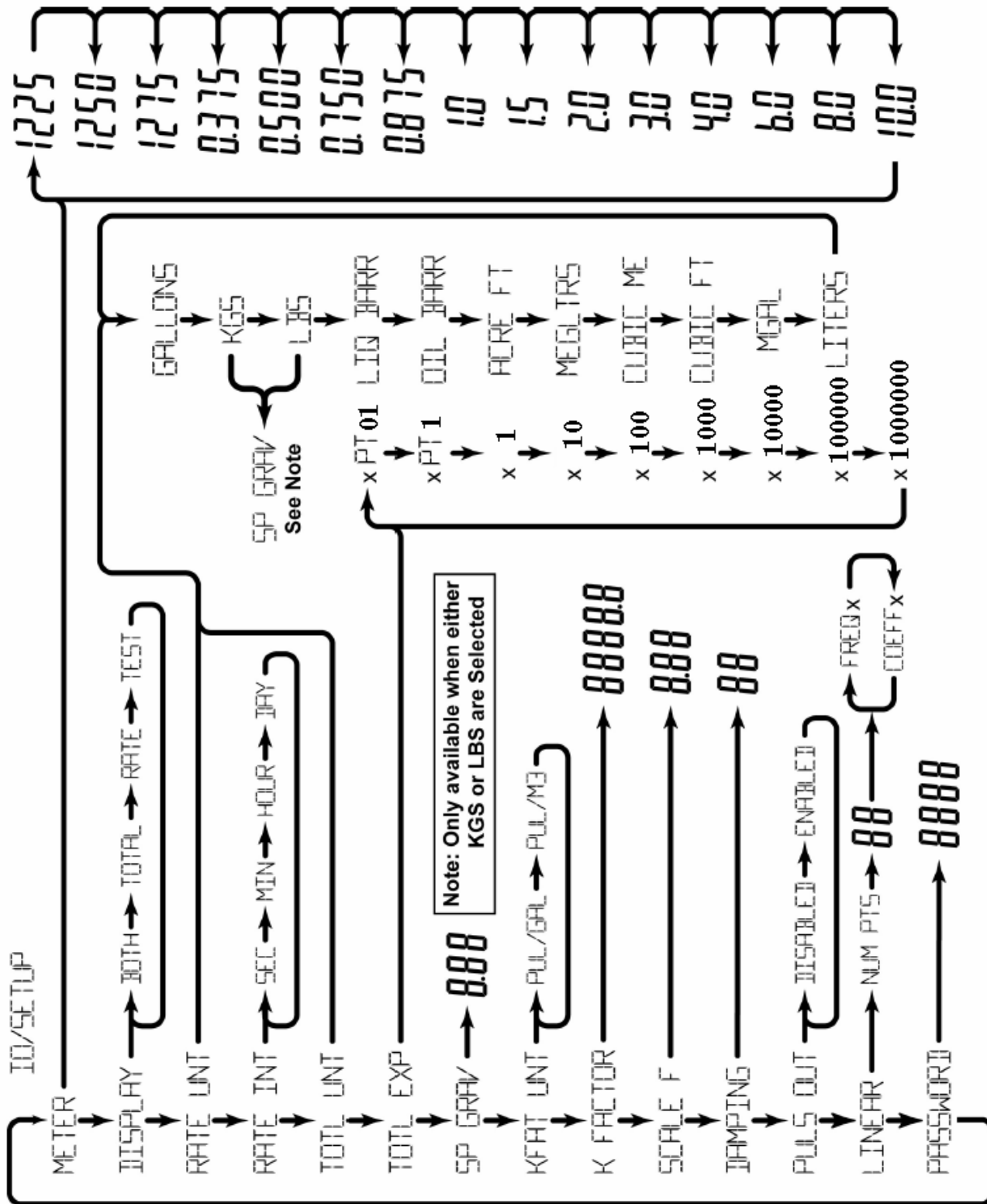

FIGURE 4 - PROGRAMMING MENU

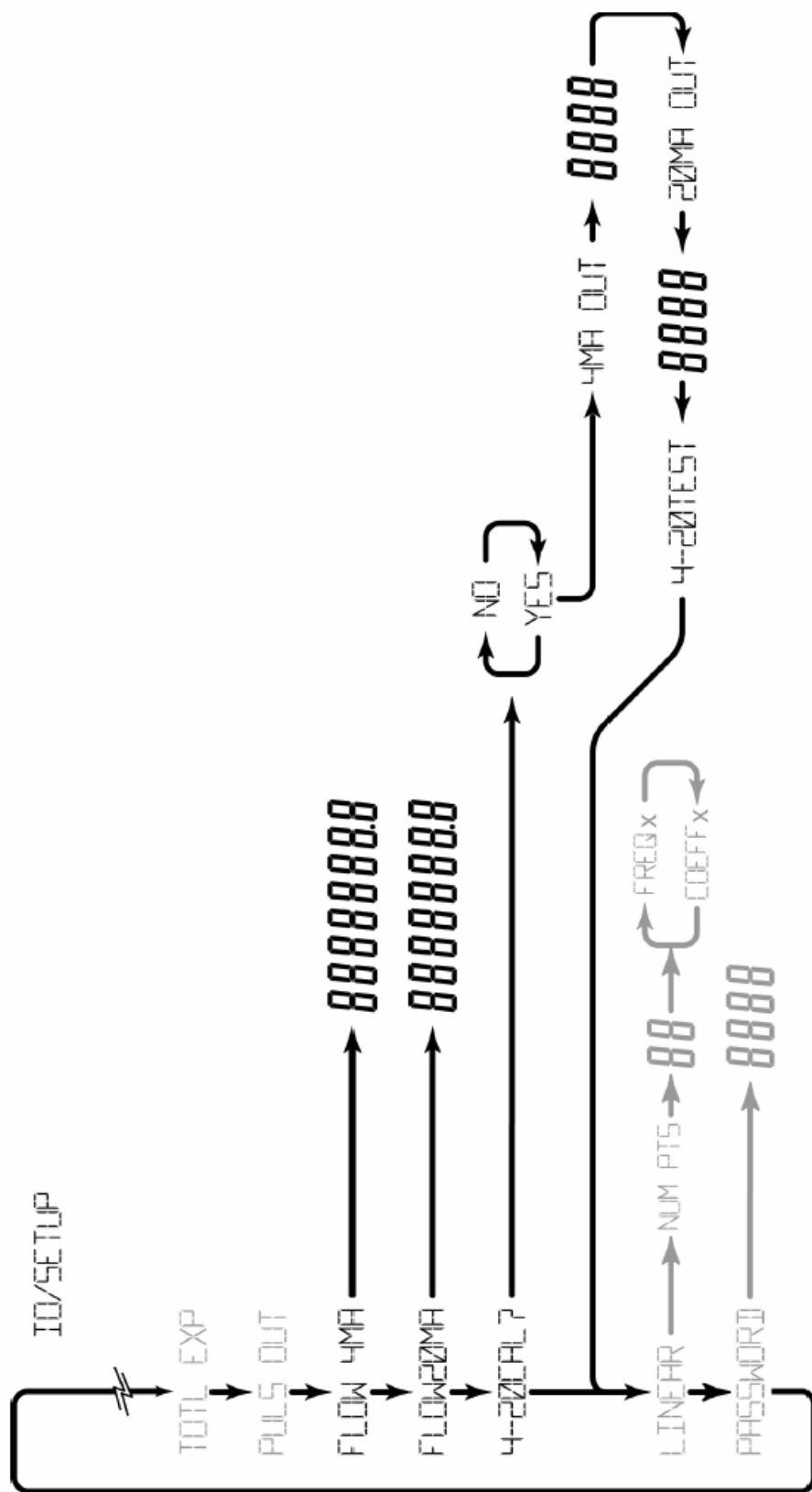

FIGURE 5 - PROGRAMMING MENU (4-20 MA)

# Troubleshooting

## 1) No LCD Display

- For Battery powered version  
Check Battery Voltage. Should be 1.5VDC (replace is low or bad).
- For Loop powered version  
Check for current flow in the loop.  
Check polarity of the current loop connections for proper orientation.

## 2) No Rate or Total Displayed

- Check connection from meter pickup to display input terminals.
- Check turbine meter rotor for debris. Rotor should spin freely.
- Check Programming of Flow Monitor.
- Check to see that the minimum flow rate is being met for the current meter in use, otherwise, the flow meter will not accurately send pulses to the flow monitor.

## 3) Flow rate display reads a constant reading all the time

- This is usually an indication of external noise. Keep all AC wires separate from DC wires.
- Check for large motors close to the meter pickup.
- Check for radio antenna in close proximity.
- Try disconnecting the pickup from the monitor pig tail. This should stop the noise. If so, then try re-orientating the meter to a new location.

## 4) Flow rate indicator bounces

- This usually indicates a weak signal. Replace pickup and/or check all connections.
- Examine K-Factor.

| Default K-Factor Values |                  |             |             |
|-------------------------|------------------|-------------|-------------|
| Meter Size              | Default K-Factor | Lower Limit | Upper Limit |
| 0.375                   | 20,000           | 16,000      | 24,000      |
| 0.500                   | 13,000           | 10,400      | 15,600      |
| 0.750                   | 2,750            | 2,200       | 3,300       |
| 0.875                   | 2,686            | 2,148       | 3,223       |
| 1.000                   | 870.0            | 696.0       | 1,044       |
| 1.500                   | 330.0            | 264.0       | 396.0       |
| 2.000                   | 52.0             | 41.6        | 62.0        |
| 3.000                   | 57.0             | 45.6        | 68.0        |
| 4.000                   | 29.0             | 23.2        | 35.0        |
| 6.000                   | 7.0              | 5.6         | 8.0         |
| 8.000                   | 3.0              | 2.4         | 4.0         |
| 10.000                  | 1.6              | 1.3         | 2.0         |

## General Notes on Scaling

This information is supplied as a general introduction to the basic concepts used to scale rate displays. The applicability of the information is dependent of the type and capabilities of the specific display/monitor used.

Flow meters producing an electronic signal are normally supplied in one of two output formats. The pulse format generates some form of alternating signal that can be “raw,” that is no amplification or wave shaping can be done prior to transmission to the readout. The output pulse rate is related proportionally to flow rate. Pulses can also be modified to produce higher output amplitudes or specific wave shapes.

The other output format is an analog signal. This is a continuously variable, voltage or current signal that is normally scaled to the dynamic range of the flow meter. Typical analog signals are 0-5VDC, 0-10VDC, and 4-20mA. The analog signals may or may not be derived from a raw pulse signal produced by the flow meter.

Scaling for any of these input signals always requires at least two scaling points for a linear process, a zero or minimum flow point and the maximum flow point. Additionally each scaling point has two components. The first is the actual input signal value and the second is the desired display value at that input signal, for that scaling point.

For example, a pulse output flow meter has a flow of 50GPM at a pulse rate of 100Hz. The actual input signal is the 100Hz figure but allowing the display to read “100” would be meaningless to the operator. The solution to this problem is to “scale” the display to “read” 50 (GPM) when the input is 100Hz.

### **Pulse Output Signals for Linear Processes (for applications where linearization is not necessary)**

Pulse output signals are related to flow rate by a constant, usually referred to as the “K-Factor.” The K-Factor is reported as the number of accumulated pulses that represents a particular volume such as gallon or liter. K-Factors are indicated in pulses per unit volume or counts per unit volume. An example of a K-Factor, normally supplied by the meter’s manufacturer, might be 2000 counts per gallon.

The K-Factor is correlated to flow through a simple mathematical relationship

$$\text{Frequency} = \text{K-Factor} \times \text{Volume per unit of time} \div 60$$

Using the previous example of 2000 counts per gallon and further assuming this meter has a maximum flow rate of 25GPM, the formula can be rearranged to calculate the input frequency required for a scaling point as follows.

$$\text{Frequency} = 2,000 \times 1(\text{gallon}) \div 60 = 33.333\text{Hz at 1GPM}$$

Given that the meter has a maximum flow rate of 25GPM the maximum frequency would then be:

$$\text{Frequency} = 2,000 \times 25(\text{gallons}) \div 60 = 833.333\text{Hz at 25GPM}$$

A programmable display requires at least two points. The first point is going to be the zero or minimum flow and the second would normally be the maximum flow rate. For the imaginary flow meter used in the example above, the scaling would be as follows:

|                                   |   |        |
|-----------------------------------|---|--------|
| Input Value for Scaling Point 1   | = | 0      |
| Display Value for Scaling Point 1 | = | 0      |
| Input Value for Scaling Point 2   | = | 833.33 |
| Display Value for Scaling Point 2 | = | 25     |

**Pulse Output Signals for Non-Linear Processes  
(for applications that can benefit from linearization)**

Few flow meters actually behave in a linear way. There is always some uncertainty about the “exact” flow at a given reported input value. For many common flow measurement applications the assumption of linear flow is adequate for the process being measured. When higher accuracy is required, a technique called “Linearization” is often employed.

When the flow meter is being calibrated, multiple data points are obtained for the particular meter being tested. Atypical five point calibration run is displayed below.

| <b>GPM</b> | <b>AVG<br/>Frequency</b> | <b>UUT Hz<br/>Counts/GAL</b> | <b>UUT K(Hz*60)/NK<br/>GPM</b> | <b>ERROR<br/>% FS</b> |
|------------|--------------------------|------------------------------|--------------------------------|-----------------------|
| 15.00      | 769.7                    | 3,078.59                     | 14.90                          | -0.65                 |
| 9.06       | 466.1                    | 3,086.75                     | 9.03                           | -0.38                 |
| 5.49       | 285.2                    | 3,118.64                     | 5.52                           | 0.65                  |
| 3.32       | 171.7                    | 3,103.95                     | 3.32                           | 0.17                  |
| 2.00       | 103.6                    | 3,101.80                     | 2.01                           | 0.10                  |

$$\text{UUT} = \text{Unit Under Test}$$

If this meter produced an actual linear output, the K-Factor calculation for the Unit Under Test would be exactly the same for each measurement point. Inspection of the UUT Kin the example above shows that this is not the case and indicates that this meter is not a perfectly linear device.

Many programmable displays allow for linearization and can provide a better match of the displayed flow values with the actual flow values by incorporating more measurement points. In the example, the unit would be programmed for six points, the five data points and a zero point, and use pairs of input values to accomplish the linearization.

## Blancett B2800 Flow Monitor Part Numbering Information

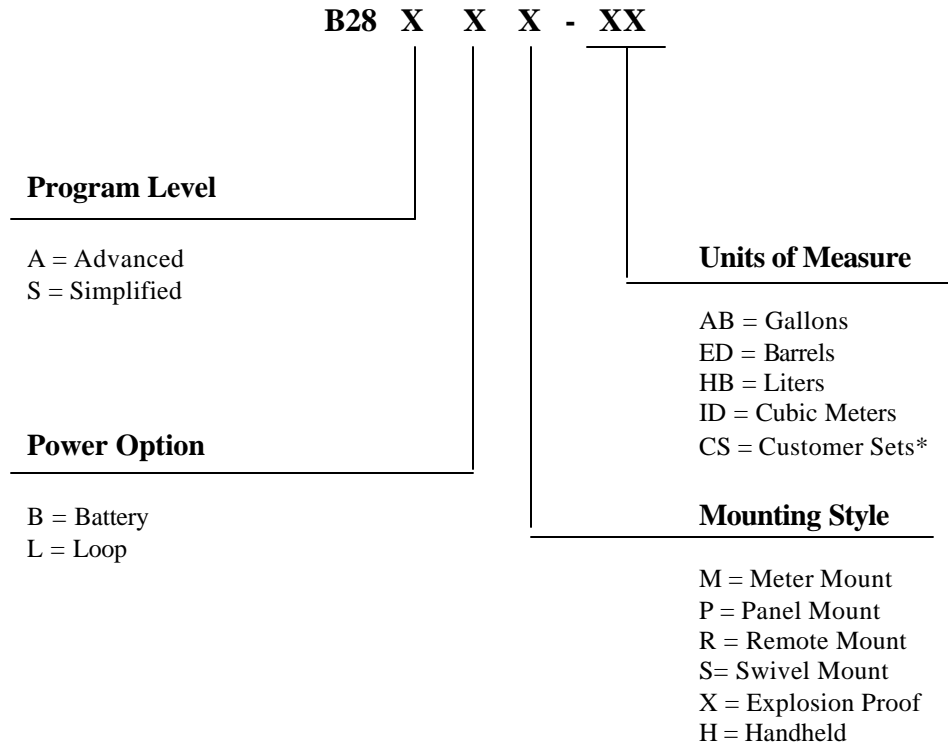

\*Note: Advanced B2800 Monitors only. The default is gallons per minute.

### Explosion Proof - Accessories

| Component            | Part Number |
|----------------------|-------------|
| Enclosure            | B280635     |
| Battery              | B280601     |
| Battery Holder       | B280634     |
| Battery Tie Wrap     | B228036     |
| Cap Plug – 3/4"      | B118236     |
| Desiccant Pouch      | B220141     |
| Pickup Cable         | B222-121    |
| Bell Reducer         | B240657     |
| Battery Mount Plate  | B280618     |
| Adaptor Bridge Plate | B280677     |
| Hex Standoffs        | B280667     |