



Programming and Installation Manual
for
Model: B2600 Flow Monitor
EZ / PRO / PLUS



Intrinsically Safe for use
in Hazardous Locations
Class I, Division 1, Groups: A,B,C and D



CE: EN 61326-1: 1997

Blancett Fluid Flow Meters

Print Version 1.04.07 9/27/2000
Part # 228902

Table of Contents

TABLE OF CONTENTS 2

SPECIFICATIONS 3

OPERATING THE B2600..... 4

THE RUN MODE FOR ALL MODELS 4

THE (PRO) PROGRAMMING MODE 5

THE (PRO) B2600 FLOW CHART..... 6

THE (PLUS) B2600 FLOW CHART 9

PROGRAMMING AND INSTALLATION INSTRUCTIONS..... 12

TYPICAL ANALOG WIRING DIAGRAM 13

METER MOUNT DIMENSIONS AND FACEPLATE LAYOUT 14

REMOTE MOUNT DIMENSIONS AND FACEPLATE LAYOUT 14

DOME CONNECTOR HOLE PLACEMENT 15

BATTERY DESCRIPTION 16

BATTERY BOARD REPLACEMENT PROCEDURE..... 16

TROUBLE SHOOTING SECTION 17

B2600 EZ TERMINAL WIRING 19

B2600 PRO AND PLUS TERMINAL WIRING..... 19

BASIC WIRING SCHEMATICS FOR PRO AND PLUS 20

INTRINSIC INSTALLATIONS 21,22

Specifications

- ▼ **Power Supply:**
 - (1) "D" size 3.6 Volt Lithium battery back for PRO and PLUS models
 - (1) "C" size 3.6 Volt Lithium battery pack for the EZ model
- ▼ **External Power Connections are provided:**
 - Input Voltage – 8.5 to 30 Vdc (Diode protected)
 - Current draw – less than 1 mA (350 uA typical)
- ▼ **Alpha-Numeric Rate and Totalization Display:**
 - Fixed or toggle modes of operation for Flow Rate and Totalizer display
 - 8 digit, .75" high numeric display
 - 8 digit, .38" high alpha display
- ▼ **Output Signal (Standard on PRO and PLUS models)**
 - Pulse output advances with least significant digit of Totalizer
 - Pulse Type = Opto-Isolated open collector transistor
 - Max. Voltage = 30 Vdc
 - Pulse Width OFF = 20ms / Max pulse rate 25Hz
 - Current (OFF State) = 0.9 V drop @ 5.0 mA or 0.7 V drop @ 0.1 mA
 - Pulse Output Divider: +0.1, + 1.0, +10, +100 or OFF.
 - Note: select OFF for Max. Battery life
- ▼ **Accuracy**
 - 0.01% Reading ± 1 Count
 - Temperature Drift = 50ppm / °C (Worst Case)
- ▼ **Output Cards**
 - Consult Factory for B2600 Plus Output Card Options
- ▼ **Mounting Style**
 - Meter Mount NEMA 4 Enclosure
 - Remote Mount NEMA 4 Enclosure
 - Panel Mount Enclosure
 - Portable Enclosure
- ▼ **Environmental:**
 - OPERATING TEMPERATURE
 - -22° F (-30° C) to 158° F (70° C)
 - HUMIDITY: 0-90% Noncondensing
- ▼ **INPUTS:**
 - MAGNETIC PICKUP INPUT:
Frequency Range: 0 to 3500 Hz
Trigger Sensitivity: 30 mV p-p
Over Voltage Protected: ± 30 VDC
 - RESET INPUT (contact closure to common):
Internal Pull-up Resistor: 100 K Ω to +3.6 VDC
High (logic 1): Open or 4-30 VDC
Low (logic 0): Less Than .5 VDC
Minimum On: 25 msec

Operating the B2600

The Blancett B2600 flow monitors utilize two modes of operation. These are referred to as the **Run** mode and the **Program** mode. Both the Run mode and the Program mode display screen enunciators confirming the state of the monitor. A quick glance at the lower left hand corner of the LCD screen will confirm operating status. Normal operation will be in the **RUN** mode. To access the programming level, press and hold the Enter key until the first programming screen is displayed. After programming the flow monitor with the necessary information, a lock out feature can be turned on to prevent unauthorized access or changing the meter specifications.

The Run Mode for all Models

When in the run mode, there are only four keys that are operational. Three of these keys are described here. The display toggle feature uses the **AUTO** and **MANUAL** keys and for resetting the totalizer, the **RESET** key is used.

This is a description of the **DISPLAY TOGGLE** functions. The **AUTO** and **MANUAL** keys on the faceplate are used for programming the display mode. While the monitor is in the **RUN** mode, an operator can momentarily press one of these keys down and the display mode will change. Pressing the **AUTO** key will allow the LCD display to automatically toggle back and forth from the flow rate screen to the totalizer screen. The display toggle rate is five seconds. If the operator wishes to leave the display on one screen continuously, he may press the **MANUAL** key. Pressing the **MANUAL** key will disable the toggle mode. For every press of the manual key, the display will alternate between continuous rate display to continuous display of the total screen.

To verify a display mode you will see **MANUAL** or **AUTO** momentarily display after pressing the appropriate key. After you see this you can release holding that key. You will now be in the mode you selected. To toggle between flow and total in the manual mode repeat pressing of the manual key will switch you between the two screens.

Resetting the flow totalizer using the **RESET** key. Pressing the Reset key will reset the totalizer. This function can be disabled by turning the lock code on. If the monitor is locked and the **RESET** key is pressed you will be prompted to enter in a lock code. The correct lock code must be entered in before the Total can be reset. After the correct lock code has been entered then the Total will be reset to zero.

The (EZ and Pro) PROGRAMMING MODE

(Refer to the flow chart diagram in this manual)

While in the RUN mode, pressing the ENTER key will allow access to the programming level. If a lock code has been previously programmed, then Screen #1 will apply. If no lock code has been programmed, then Screen #2 will apply.

Screen #1 – **LOC CODE** / lock code. If a lock code has been programmed, then this will be the first screen you will see after pressing the ENTER key. You must enter in the correct lock code to proceed to the programming level. Enter in the lock code to continue. If the lock code is incorrect or if the user presses “Enter” before entering in the correct lock code, then the unit returns to the run mode. If the lock code was not turned on then this screen will not appear.

Screen #2 – **MTR SIZE** / meter size. This screen allows a user to scroll through standard meter sizes. Use the up or down arrow keys to view the meter model options. You can scroll up or down in a loop until you find your choice. Once a meter size is found then press the ENTER key.

Screen #3 – **K FACTOR**. A generic K-factor for the meter size selected in screen #2 will be displayed. You can use the up, down, left or right arrows to manipulate the number value. The right or left arrow keys move the cursor to the next digit location. When the K-factor number is correct, press the ENTER key to save your value.

Screen #4 – **Units of Measure**. Use the up or down arrows to scroll through the units of measure. For example, to display the total in gallons and the flow rate in gallons per minute select **GPM/GAL**. Press the ENTER key to save your selection. Other units of measure for the (EZ) version are **LPM/LIT**, **M3PD/M3** and **BPD/BBL**.

Screen #5 – **OUTPUT X** / Pulse output. (**Pro model only!**) This will activate the pulse out function. You can also choose a multiplier. For example selecting .1 will output a pulse every 1/10th of the totalized units of measure. Options for units of measure: **100, 10, 1 or .1.** (note: **The hardware and menu option is not provided with the EZ version. There is no pulse output.**)

Screen #6 and #7 – **UNLOCKEd** or **LOCKEd**. In **Screen #6** you will choose between unlocking or locking the unit. Using the up or down arrows will toggle between the two options. If the screen says locked and the enter key is pressed then you will be asked for a lock code. From this screen you can enter or change the lock code number. When locked, the correct lock code must be entered to regain access to the programming mode. This also controls the reset key function. Totals cannot be reset if the lock code is enabled. To reset the totals when the monitor is locked a lock code must be entered after the reset key is pressed.

The (EZ) FLOW CHART

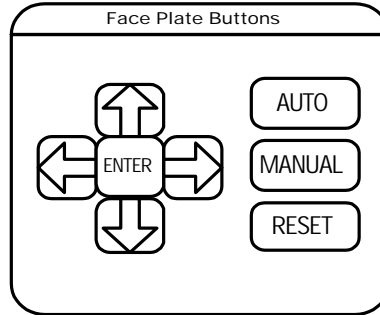
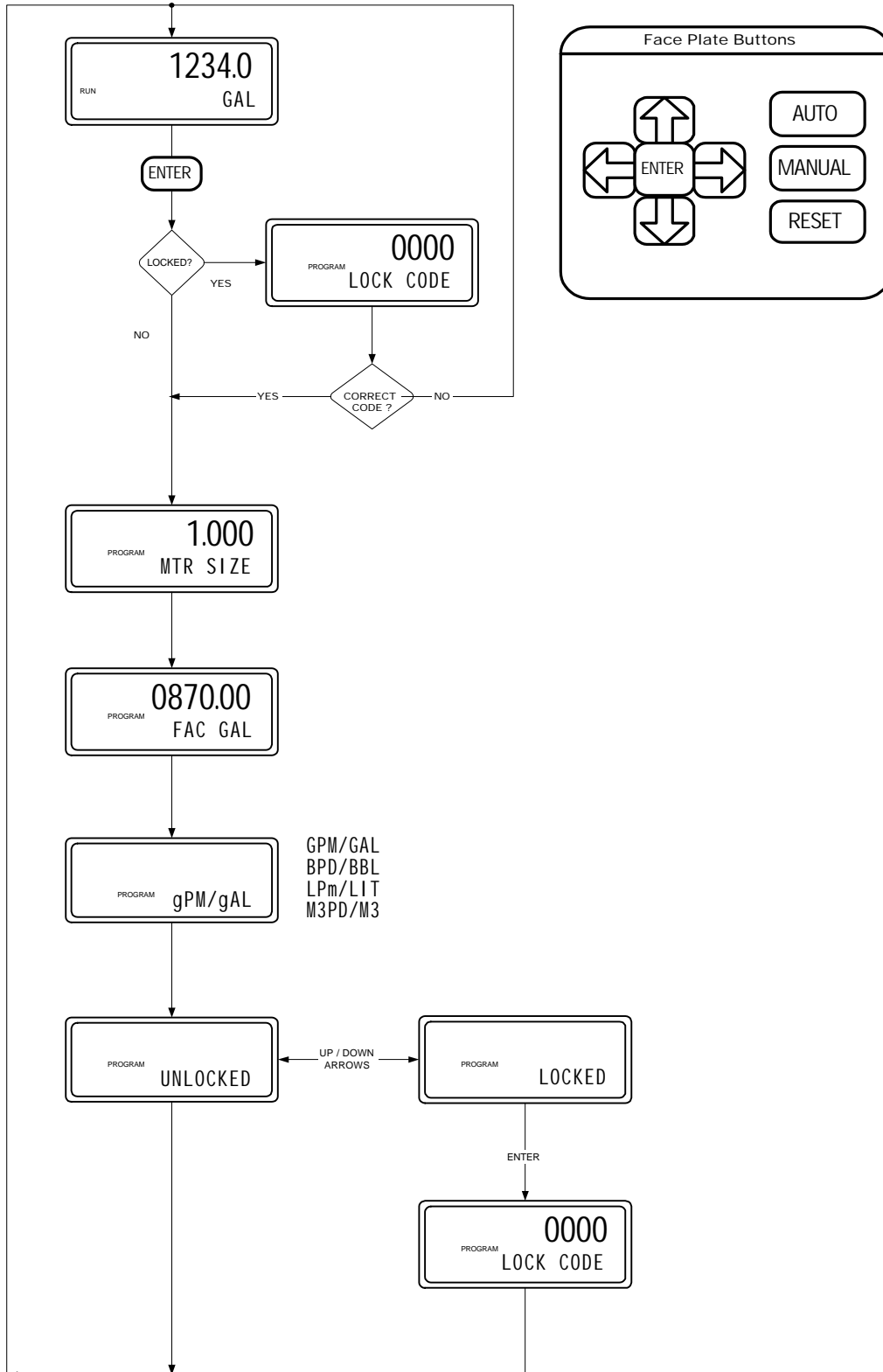

The (PRO) FLOW CHART

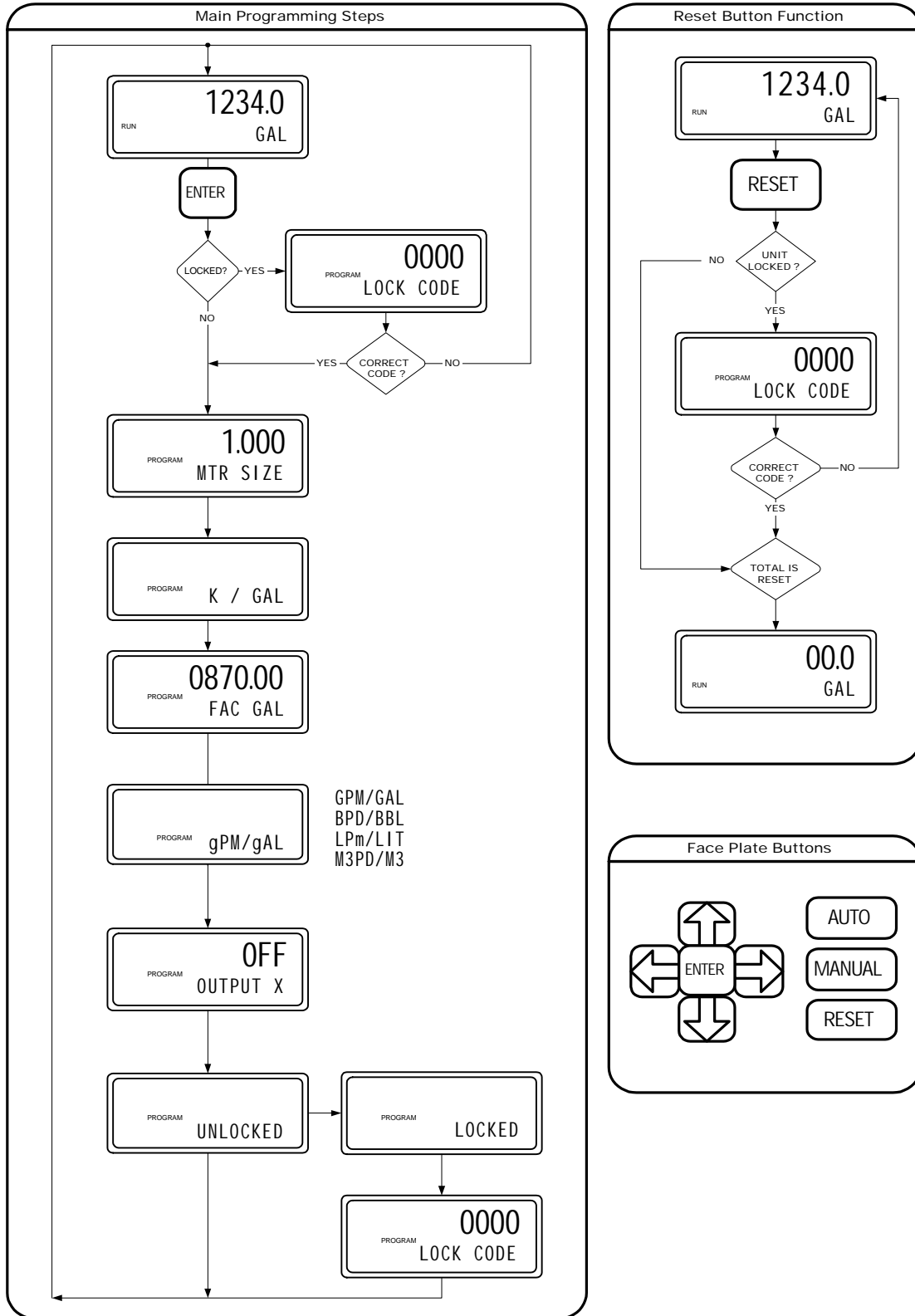

The (PLUS) PROGRAMMING MODE

(Refer to the flow chart diagram in this manual)

Screen #1 – “LOC CODE” / lock code. If a lock code has been programmed previously then this will be the first screen you will see after pressing the “ENTER” key. Enter the lock code to continue to the programming procedure or press the “ENTER” key to return to the run mode. If no lock code was set up previously then this screen will not appear.

Screen #2 – “MTR SIZE” / meter size. This screen allows a user to scroll through standard meter sizes. Use the up or down arrow keys to view the meter model options. You can scroll up or down in a loop until you find your choice. Once a meter size is found then press the “ENTER” key.

Screens #3 and #4 – “K FACTOR / 10 POINT”. The advanced programming version offers a choice of either selecting an AVERAGE K-FACTOR or using a 10 POINT LINEARIZER for meter calculations. Choosing the average K-factor for the meter size will use just an average k-factor for the entire flow range. Choosing the 10 point linearizer will enable the user to enter in a factory calibration of Hz versus K-factor for a meter. These 10 points will be used to linear interpolate the meter over the input frequency range. **(NOTE: The entered values must be entered in ascending order.)** From the Calibration Sheet start with the smallest Hz value and it’s associated k-factor and enter this into HZ1 and K1-factor. Continue in this manner until all the points are entered. If less than 10 points are used then on the last entered value continue to hit the ENTER key until the remaining fields have been filled.

Screen #5 – Units of Measure. Use the Left and Right arrows to select between STANDARD UNITS or SPECIAL UNITS OF MEASURE. If selecting the standard units of measure then proceed to Screen #6A1. If you select the special units of measure proceed to Screen #6B1

Screen #6A1 – Selecting standard units of measure. Using the up and down arrow keys you can choose from a list of standard units. These are GPM/GAL, BPD/BBL, LPM/LIT or M3Pd/M3. After finding the unit of choice then use the ENTER key to save. Jump to instructions for Screen #7.

Screen #6B1 – “rATE “. From this screen you can using the up and down arrows select between GALLONS, BARRELS, LITERS, CUBIC METERS, CUBIC FEET, POUNDS or UNITS. Press the ENTER key to save your selection.

Screen #6B2 – “rATE Int” / Rate Interval. From this screen you will be able to choose between different accumulating periods of time. Your selections are SECONDS, MINUTES, HOURS or DAYS. Make your choice and press the ENTER key.

Screen #6B3 - “rATE dEC” / Rate Decimal. This screen will allow a user to select the decimal location for displaying the rate. Make your selection using the left and right arrows and ENTER.

Screen #6B4 - “tOtAL” / Total Units. This screen allows you to choose the units displayed for the totalizer. Using the up and down arrows choose from BARRELS, GALLONS, LITERS, CU METER, CU FEET, POUNDS or UNITS. Make your choice and ENTER. If you choose the UNITS option during the RUN mode the screen will display “UNIT” for the description.

Screen #7 – “OUTPUT X” / Pulse output. This will turn on and off the pulse output and will also select a factor. For example, selecting “.1” will output a pulse every 1/10th of a unit of measure.

Screen #8 – “LOCKEd” / “UNLOCKEd”. From this screen you can enable or disable the lock code feature. If the lock code is enabled, a unique 4 digit number must be entered. Record this number. You will only be allowed access to the programming level by entering the correct lock code.

After Screen #8 the unit will return to the RUN mode of operation. See RUN mode operation for more detail.

The (PLUS) FLOW CHART

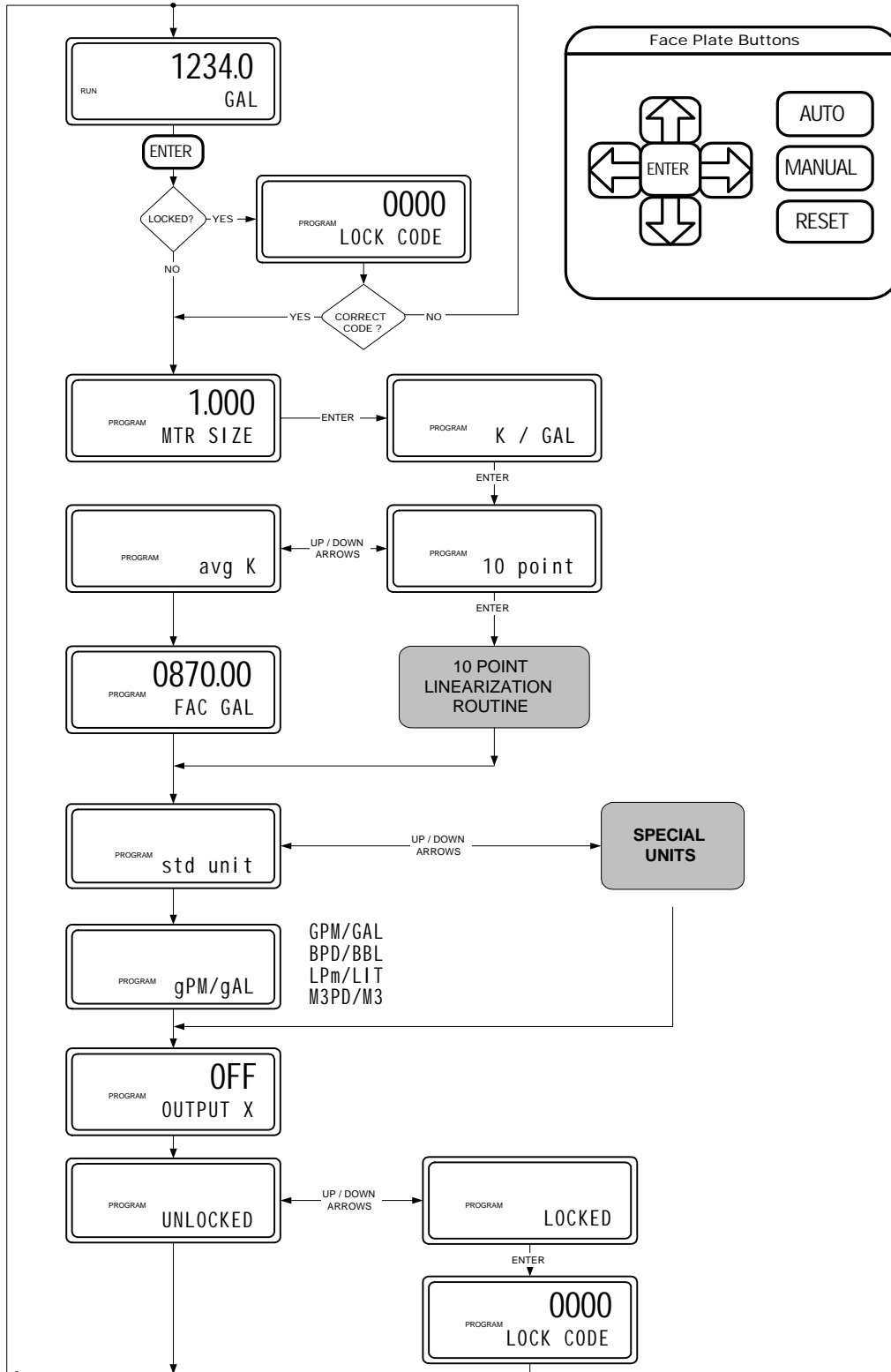

BLANCETT FLUID FLOW METERS

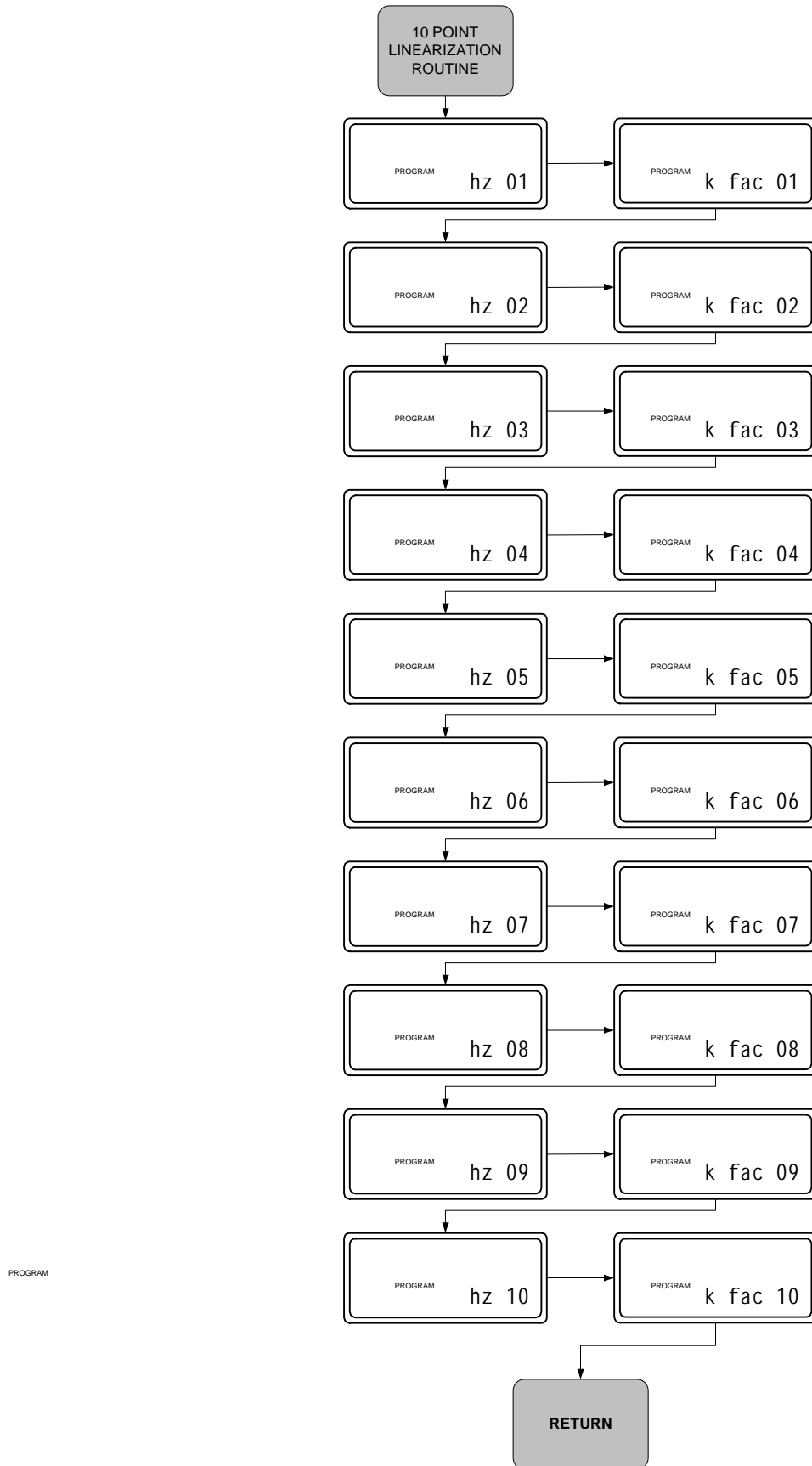

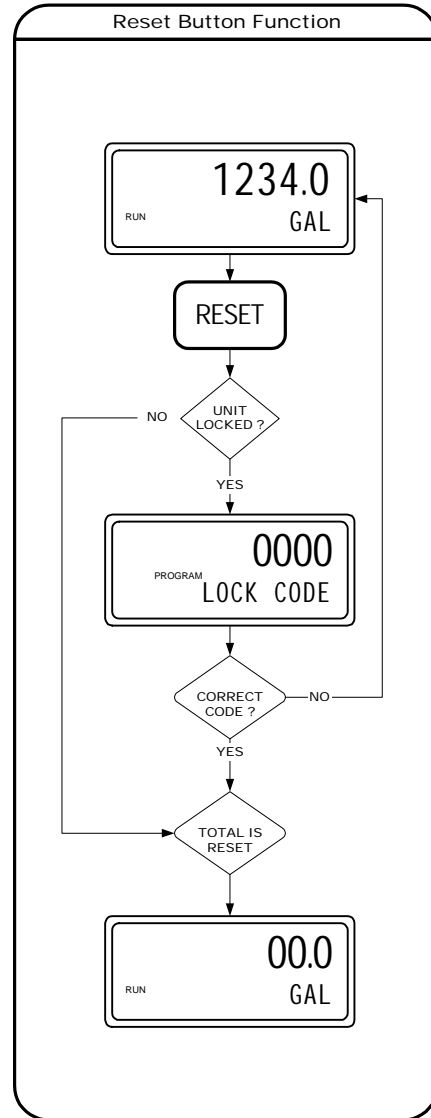
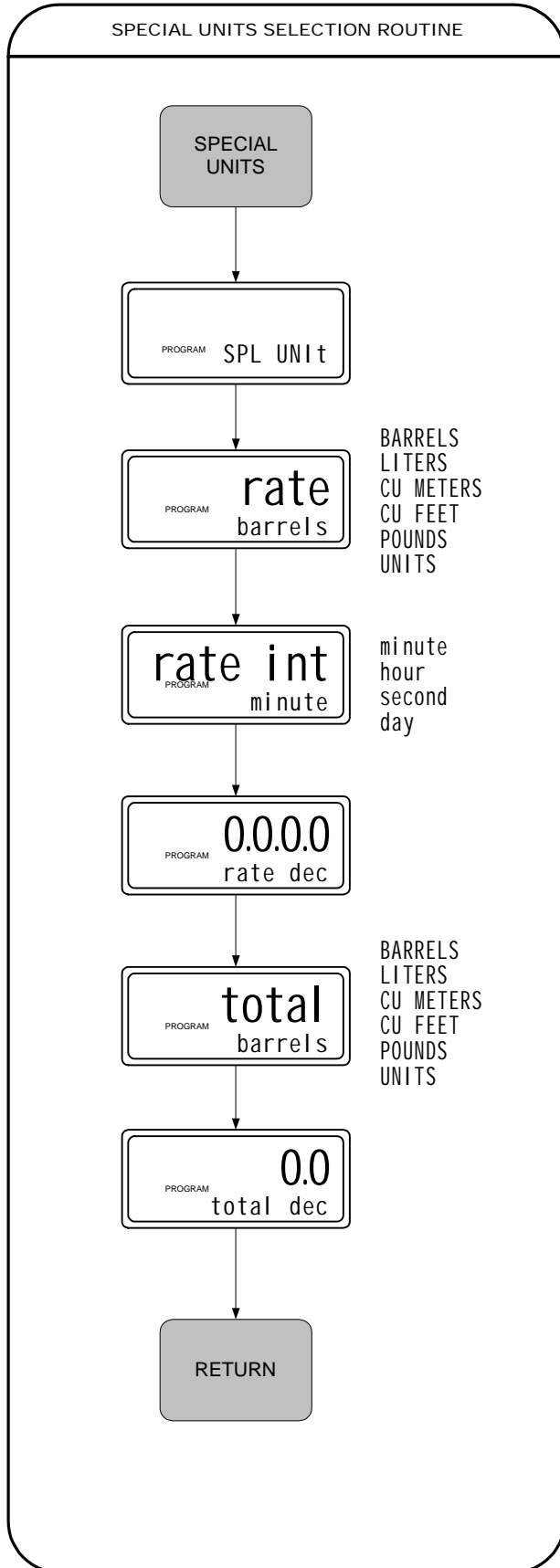

Programming and Installation Instructions
for the Analog Output Module (B2600 Plus)
Version 1.04 firmware

Reference Drawing: B2604C-420RB-001.SCH 6/13/2000

Intro: The Blancett B2600 Plus version of flow monitors is capable of expanding input and output functions. Multiple modules are available for selection and can be plugged into the monitor. The monitor is designed to automatically recognize what module is plugged in and provide the necessary setup screens to configure the added device. The plug and play feature makes installing and setting up any module a snap. Consult factory for your needs on module selections.

Output Description: The Analog Output module for the B2600 monitor is a two wire analog output representing instantaneous flow. The module will be configured for a 4-20mA. output from the factory. The module can also provide a 0-16ma output. Using a terminating resistor in combination with the current output, a voltages output can be obtained. To calculate the desired voltage and resistor combination a simple calculation is used. $(E)\text{voltage out} = (I)\text{current} \times (R)\text{resistor}$ or $E=IR$. Some of the possibilities are 0-5vdc, 1-5vdc, and 0-10vdc.

Installation and programming: The analog module can be plugged in and removed at any time. It is not necessary to remove or turn off power to the monitor. The module will be recognized and configured automatically for the current meter being used. The default setting is zero flow is represented by zero output and maximum flow is represented by maximum output from the module. With in the configuration two additional screens will appear with the default values. These values can be change at anytime to meet the user's specific needs. The analog module is designed to plug into the right port (module port#2) on the main B2600 circuit board. Easy snap insertion is provided through the use of snap standoffs. Line the module up over the right port and press firmly down until snaps lock. After module is plugged in then it can be configured if needed. Using the front keypad press the enter key to access the configuration menu. Using the enter key step through the various screens until you see MOD(#) LOW or MOD(#) HI. These are the two added screens necessary to setup the analog module. The number you enter represents the flow rate in units previously selected in the configuration. If GPM/GAL was selected, then enter your value in GPM. When done press the enter key to accept your selection. Exit the configuration by entering the run mode. This completes the steps necessary for programming the analog module.

Wiring: The analog module is easily interfaced to monitoring devices using a two wire cable connection. Power and signal are combined on two wires cutting down on cost and complexity. A wide power source range is also provided. The range is 3.3vdc to 30.0vdc. Refer to the appropriate wiring schematic for further details. For hazardous locations refer to drawings BEP67-20 and BEP67-21.

Typical analog wiring diagram

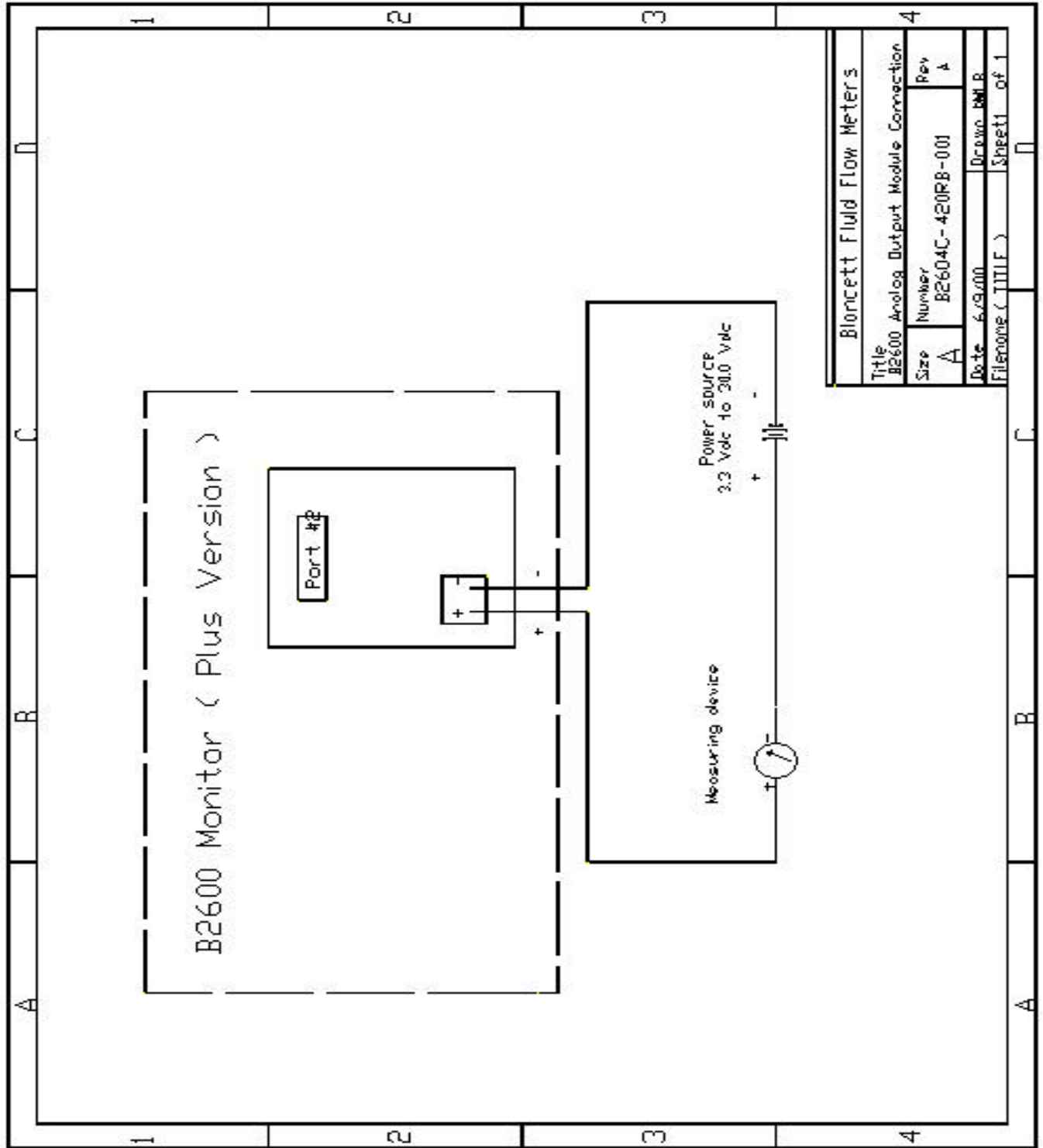

Meter Mount Dimensions and Faceplate Layout

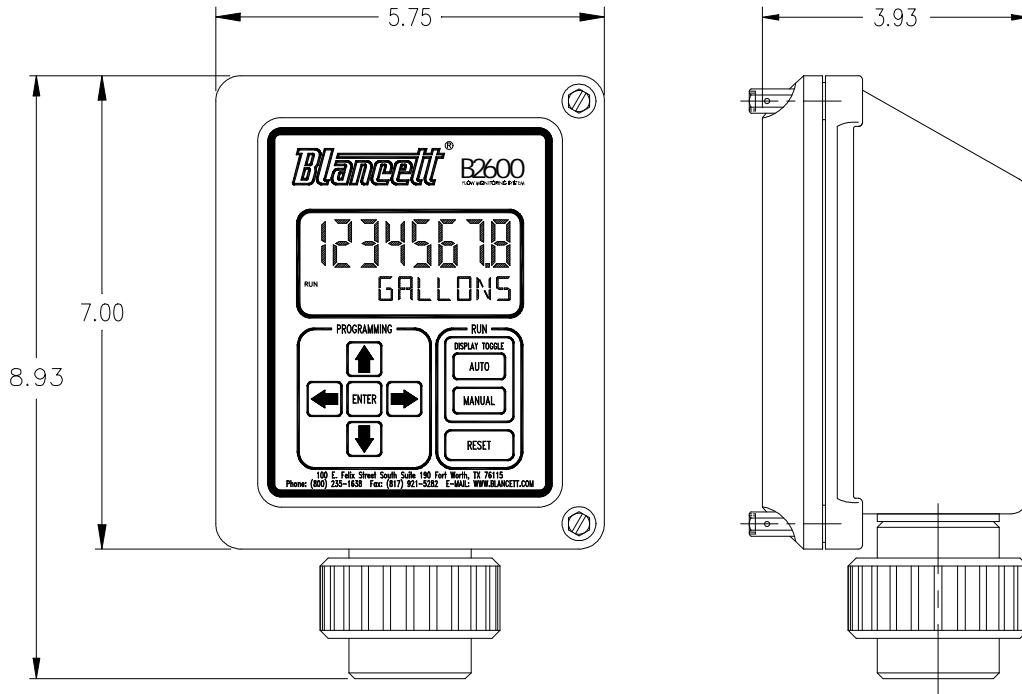

Remote Mount Dimensions and Faceplate Layout

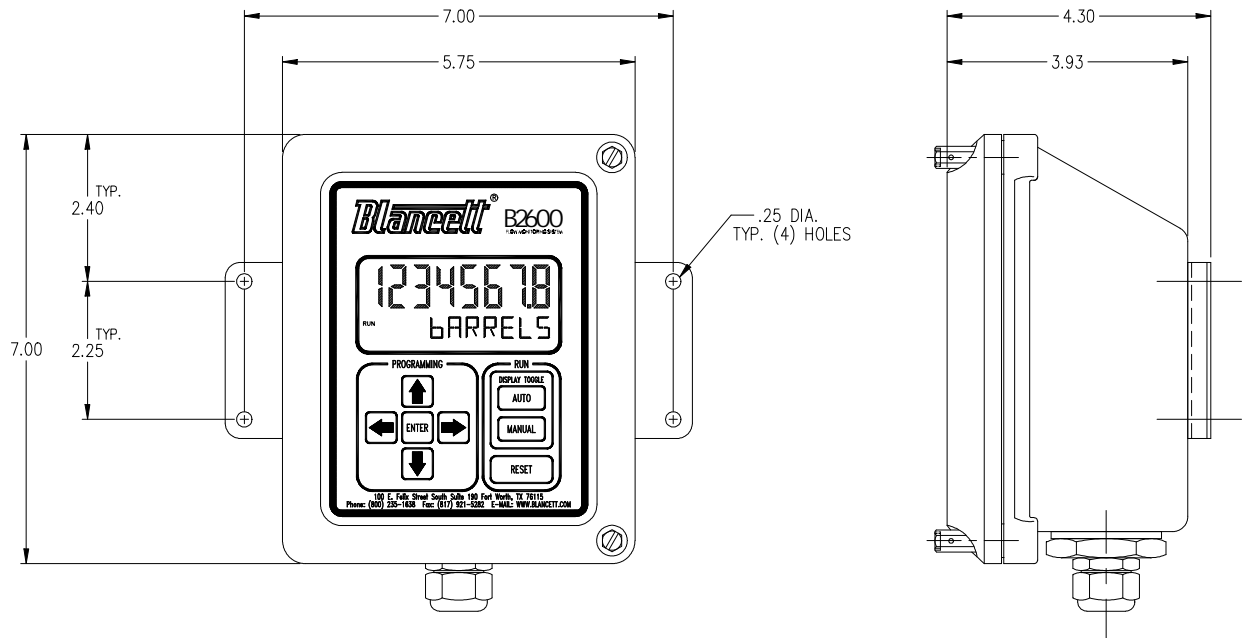

Blancett Model B2600 Flow Monitor External Wiring Access Drawing

The Blancett Model B2600 Flow Monitor can be assembled in many configurations. If the customer wishes to access the monitor box for external wiring, Blancett does include a plastic connector for this purpose. The drawing below shows the location and dimensions necessary to modify the enclosure for this external access. However, the customers may choose to utilize their own hardware to accomplish this external access. In this case, please refer to the drawing below for the correct position to drill the access hole. When this modification to the monitor enclosure is made, please make sure to use sufficient gaskets or sealant to maintain the weather-tight integrity of the enclosure. Failure to do so may result in unwanted corrosion of the circuitry contained in the enclosure.

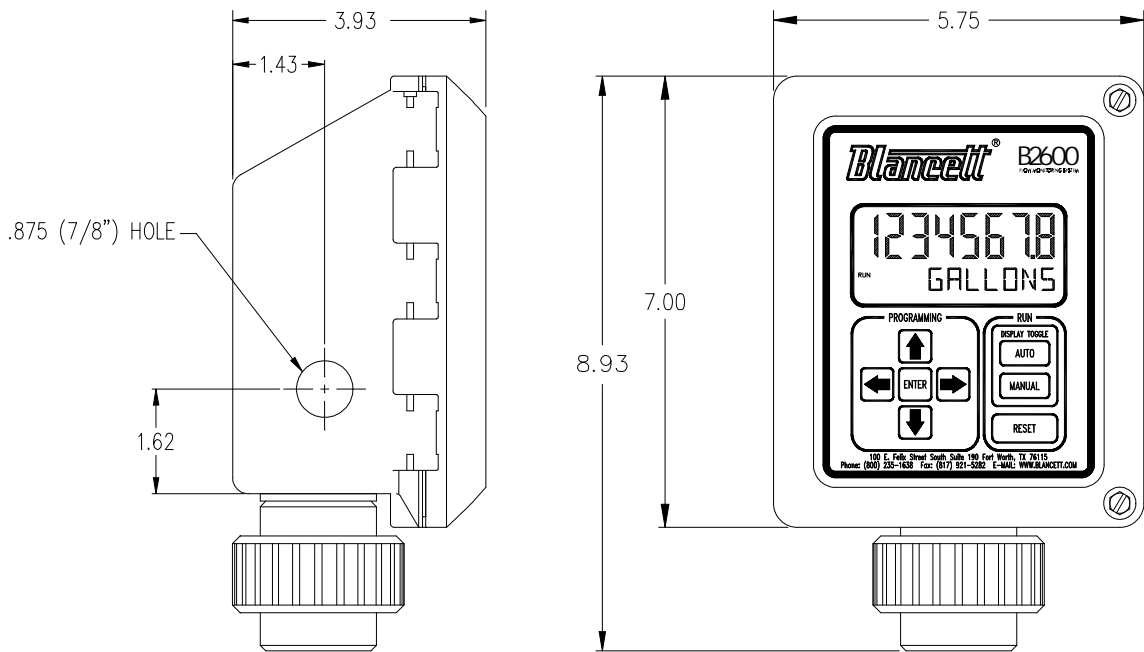

Note: The .875 (7/8") diameter hole note on the drawing is necessary when utilizing the plastic connector supplied by Blancett. Use the centerline dimensions only when using different hardware.

Battery Description

The B2600 monitor comes with a battery pack installed from the factory. This battery pack may contain 1 D-size Lithium Battery if it is a PRO or PLUS unit. The EZ uses 1 C-size Lithium battery. The battery pack was designed to be a low maintenance item. Utilizing the outstanding performance of a Lithium battery offers best option when operating as a stand alone unit. Up to three years of operational life can be expected. If the pulse output is turned on, then this time may be less. When servicing the battery pack, only use Blancett replacement parts.

3+ Year operational life expectancy (Pulse output turned off)
 1 - Polarized 2 pin header.

Blancett Part# PRO/PLUS.....	B260607
Blancett Part# EZ.....	B260628
Voltage specification.....	3.6 Vdc
Operating temperature.....	-55C - +85C
Max 1 Sec. Pulse capability.....	100mA

Battery Board Replacement Procedure

Note: This procedure is outlined only for NON-HAZARDOUS locations!

- 1) Record totals from total screen if possible.
- 2) With a small Phillips screwdriver, remove the four mounting screws holding the battery pack.
- 3) After the screws have been removed, gently pull down and away from the main 2600 board. This battery is connected by a two pin polarized terminal block located on the back of the battery PC board. Do not use excessive force. Do not pry on with screw driver.
- 4) After old battery has been removed dispose in Approved Battery Recycle location or send to Blancett for refurbishment.
- 5) With new battery pack in hand verify connector location and compatibility.
- 6) Line up connectors and install battery board so that locking connectors engage.
- 7) Reinstalled mounting screws.
- 8) Once everything is connected and you have double checked the installation it will be time to reboot the B2600. The configuration data is held in EEPROM memory and should not need to be reentered.
- 9) After installing the battery pack the B2600 should come up in the run mode with all of the meter settings in tacked. However the totalizer data will be lost and you will have to reset the total to zero. Note: If totalizer information needs to be retained then it is possible to connect a temporary DC power source to terminals #1 and #2 reference JP4. Terminal #1 is positive and terminal #2 is negative. External supply voltage +5 to 18 VDC regulated. This will provide power to the memory even if no battery installed. Remove external power supply when finished.

Trouble Shooting Section

1) No LCD display

- Check Battery voltage. Should be 3.6vdc. (replace if low or bad)
- supply alternate supply voltage +8.5 to 30 vdc to terminals 1 & 2.

2) No rate or total displayed

- Check connection from meter pickup to terminals 4&5 (signal in).
- Check turbine meter rotor for debris. Rotor should spin freely.
- Check programming of monitor.

3) Flow rate display reads a constant reading all the time.

- This is usually an indication of external noise. Keep all AC wires separate from DC wires.
- Check for large motors close to meter pickup.
- Check for radio antenna in close proximity.
- Try disconnecting the pickup from the monitor pig tail. This should stop the noise. If so then try reorienting the meter to a new location.

4) Flow rate indicator bounces.

- This usually indicates a weak signal. Replace pickup and/or check all connections.
- Examine k-factor.

5) Totalizer remains zero all the time.

- Try disconnecting the face plate and/or external reset button. If after disconnecting, the totalizer begins counting, then this may indicate a bad faceplate reset button and/or external reset switch.

Technical Support is available through Blancett Fluid Flow Meters. Call 800-235-1638.

For returns, please contact factory or distributor and receive a RGA number. Once you have the Return Goods Authorization, then mark the package clearly with the number and return to :

Blancett Fluid Flow Meters
100 East Felix St. South Suite 190
Ft. Worth Texas 76115

BLANCETT FLUID FLOW METERS

Cross Reference Guide (2600 default Meter list)

Meter size	Default K-factor	LOWER K LIMIT	UPPER K LIMIT
------------	------------------	---------------	---------------

0.375	20,000	16000.0	24,000
0.500	13,000	10400.0	15,600
0.750	2750	2200.0	3,300
0.875	2686	2148.8	3,223
1.000	870	696.0	1,044
1.500	330	264.0	396
1.500	330	264.0	396
2.000	52	41.6	62
3.000	57	45.6	68
4.000	29	23.2	35
6.000	7	5.6	8
8.000	3	2.4	4
10.000	1.6	1.3	2
1225	31,000	24800.0	37,200
1250	9,000	7200.0	10,800
1275	2,950	2360.0	3,540

When B2600 monitors are not used on a Blancett Meters, then cross using K-factor.

B2600 EZ TERMINAL WIRING

<u>Terminal Strip Pinout</u>	<u>Device</u>
1)	
2)	
3) Magnetic Pickup Shield GND (if provided)	
4) Magnetic Pickup Input (+)	
5) Magnetic Pickup Input (-)	
6)	
7)	
8)	
9)	

B2600 PRO and PLUS TERMINAL WIRING

<u>Terminal Strip Pinout</u>	<u>Device</u>
1) Alternate DC Power In (+8.5 vdc to +30 vdc)	
2) Alternate DC Power In GND	
3) Magnetic Pickup Shield GND (if provided)	
4) Magnetic Pickup Input (+)	
5) Magnetic Pickup Input (-)	
6) External Reset GND	
7) External Reset (pull to ground to operate)	
8) OPTO Out (-) (Opto-isolated open collector output)	
9) OPTO Out (+) (Opto-isolated open collector output)	

Note: A dome connector is provided for pulse out connections. Refer to drawing provided in dome connector packaging for placement and drilling instructions.

Basic Wiring Schematics for PRO and PLUS

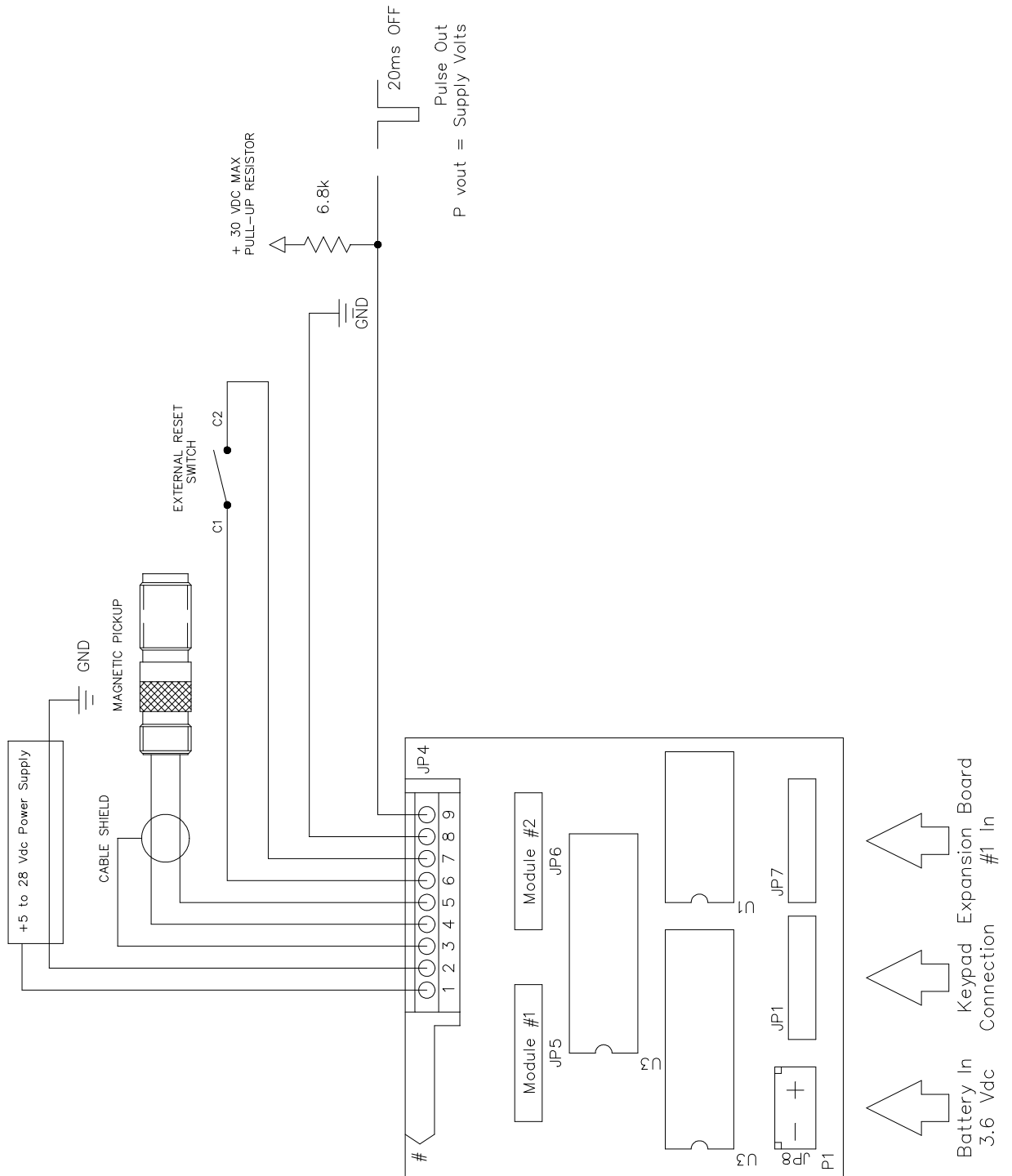

Intrinsic Installations

